



Primer

LCA-50 T2

Barrier washers 27-70 kg

T2 CONTROL

7" touch screen easy to use and fully programmable, display on dirty side.
 Screen on both sides of the machine.
 Connection USB. Free software online for programming, telemetry, data analysis, etc.
 37 languages.
 8 dosing signals as standard.

OUTSTANDING FEATURES

Automatic positioning of drum.
 2 water inlets.
 Wet Cleaning, telemetry standard.
 G-FACTOR 325 (100kg), 350 (16, 22kg), 375 (27, 35, 50, 70kg).
 Heating: electric, steam, and dual heating model (electric + steam).

EFFICIENCY

Intelligent consumption: automatic adjustment of water and soap consumptions (standard).
 Optimal loading: manual indication of weight.
 Water Recovery tanks ready: **SAVETANK XL**.
 Low water consumption.
 High G FACTOR: reduced residual moisture > reduced drying time.

CONNECTIVITY

IoT - PRIMERLINK standard.
 Remote technical service.
 Laundry management.

ERGONOMICS

Huge door opening making loading/unloading easier.
 Easy friendly drum opening by push button.
 Loading height (door base): Ø 640 (16, 22 kg), Ø 800 (27, 35, 50, 70 kg)

EASY MAINTENANCE

Electric components on the left side, mechanical components on the right side and connections on the top (protected from water and detergents).
 Central drain as standard.
 Technical menu: statistics, alarms, autotest, data recovery for technicians and maintenance.

OTHERS

2 opposed doors. Pass-through barrier washer.
 Ready to be connected to dosing pumps.
 Grey skinplate outer casing.
 Drum and vat in stainless steel AISI 304.
 Frequency inverter to control imbalance.
 CE approved product.



OPTIONS

- License IoT - PrimerLink
- Inner door open sensor LCA-27/35/50
- Inner door open sensor LCA-70
- Version with one door LCA-2750
- Pullman drum for LCA-50
- Weighing sensor system on feet LCA-27 / 35 / 50. Includes kit with 6 extra dosing signals
- 6 extra dosing signals card
- 2nd drain valve
- Ready for SAVETANK XL conn. 1" for barriers for LCA-50
- Water sampling
- Side drain valve
- Low steam pressure
- 4 compartments detergent box
- UPS option (in case of power failure)
- End of cycle light alarm
- Plinth to align the doorbase at 850mm LCA-50
- Stainless steel AISI 304 outer casing for LCA-50
- Maritime wooden packing for LCA-50
- Tension 230 III 50/60 Hz LCA-50
- Stainless steel frame for LCA-50
- maritime voltage 440 V III 50/60 Hz
- STEEL FRAME LCA-50 equipped with loading base

| DRUM | UNIT. | LCA-50 T2 | |
|----------------------------------|-------------------------|-----------------------|---------------|
| Load capacity 1:9 | Kg | 54,3 | |
| | lb | 119,8 | |
| Load capacity 1:10 | Kg | 49 | |
| | lb | 108,0 | |
| Volume | l | 489 | |
| | ft ³ | 17,27 | |
| Diameter | mm | 800 | |
| | inch | 31,5 | |
| Depth | mm | 974 | |
| | inch | 38,3 | |
| Drum compartments | Nº | 1 | |
| GENERAL DETAILS | | | |
| Washing speed | rpm | 45 | |
| Spining speed | rpm | 920 | |
| G-Factor | - | 375 | |
| T2 Control | - | 7" | |
| Double screen | - | STD | |
| Motor break | - | STD | |
| Double drainage | - | OPT | |
| DOOR | | | |
| Drum opening dimensions | mm | 640 x 515 | |
| | inch | 25.2 x 20.3 | |
| Vat opening dimensions | mm | 700 x 650 | |
| | inch | 27.5 x 25.6 | |
| Height door bottom | mm | 800 | |
| | inch | 31,5 | |
| POWER | | | |
| Motor | kW | 5,5 | |
| Electric heating (elec. mod) | kW | 36 | |
| Total electric power (elec. mod) | kW | 41,5 | |
| Total electric power (steam mod) | kW | 5,5 | |
| CONNECTIONS | | E/DUAL | S |
| Tension 230V I + N + T 50/60Hz | Nº x mm ² /A | - | - |
| Tension 230V III + T 50/60Hz | Nº x mm ² /A | 4 x 25 / 125A | 4 x 2,5 / 16A |
| Tension 400V III + N + T 50/60Hz | Nº x mm ² /A | 5 x 16 / 63A | 5 x 2,5 / 10A |
| Water inlets number | - | 3 | |
| Water inlet | inch | 1" | |
| Water pressure | bar | 3 - 5 | |
| | psi | 43 - 72 | |
| Steam inlet (steam mod) | inch | 3/4" | |
| Steam pressure | bar | 4-8 | |
| | psi | 58-116 | |
| Drain number | - | 1 | |
| Drain evacuation capacity | l/min | 160 | |
| | cfm | 5,65 | |
| Drain | inch | 3" | |
| OVERALL DIMENSIONS | | | |
| Net / Gross width | mm | 1.717 (1.869) / 1.903 | |
| | inch | 67,6 (73,6) / 74,9 | |
| Net / Gross depth | mm | 1.195 / 1.300 | |
| | inch | 47 / 51,2 | |
| Net / Gross height | mm | 1.615 / 1.720 | |
| | inch | 63,6 / 67,7 | |
| Net / Gross weight | kg | 1.063 / 1.085 | |
| | lb | 2.344 / 2.392 | |



| | | |
|--------|-----------------|-------|
| Volume | m ³ | 4,26 |
| | ft ³ | 150,3 |

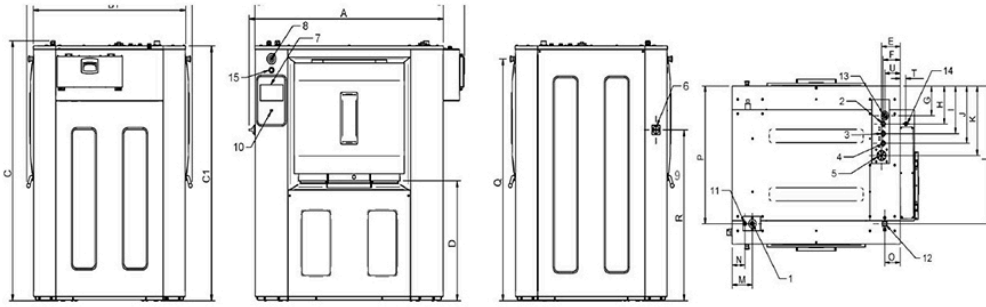

- 01. Electrical connexion
- 02. Cold water inlet
- 03. Soft water inlet
- 04. Hot water inlet
- 05. Liquid products inlet
- 06. Main switch
- 07. Control panel
- 08. Emergency stop
- 09. Door opening
- 10. USB port
- 11. Dosing pumps connexion
- 12. Steam inlet
- 13. Exhaust
- 14. Cold water for detergents box

| | A | B | C | A1 | B1 | C1 | D | E | F | G | H | I | J | K | L | M | N | O | P | Q | R | S | T | U |
|--------|------|------|------|------|------|------|-----|-----|-----|-----|-----|-----|-----|-----|-----|-----|-----|-----|-----|------|------|------|----|-----|
| LCA-27 | 1244 | 1193 | 1612 | 1201 | 1098 | 1581 | 745 | 152 | 138 | 206 | 263 | 330 | 397 | 482 | 956 | 163 | 103 | 126 | 956 | 1499 | 1059 | 1350 | 45 | 125 |
| LCA-35 | 1402 | 1193 | 1612 | 1359 | 1098 | 1581 | 745 | 152 | 138 | 206 | 263 | 330 | 397 | 482 | 956 | 163 | 103 | 126 | 956 | 1499 | 1059 | 1508 | 45 | 125 |
| LCA-50 | 1697 | 1193 | 1612 | 1654 | 1098 | 1581 | 745 | 152 | 138 | 206 | 263 | 330 | 397 | 482 | 956 | 163 | 103 | 126 | 956 | 1499 | 1059 | 1803 | 45 | 125 |

