



Primer

DP-8 T2

Professional dryers T2

T2 CONTROL

User friendly and totally programmable 4,3".
 USB Connection.
 Online platform free of charge for programming, telemetry, data analysis... thanks to the IoT.
 Videos on display (ads, instructions, etc.).
 37 languages.
 8 dosing signals as standard.

VERSATILITY

OPL <> COIN - Standard models can be programmed as OPL or coin laundry version, central pay, etc.
 SINGLE <> STACKED - Models can be stacked on top of a washer or on another dryer.
 Control panels can be assembled between both drums for better ergonomics.
 Ideal for multiple solutions: hotels, hostels, campings, coin laundries, facility services (mops), gyms, etc.
 Wet Cleaning features.

OUTSTANDING FEATURES

Reduced drying times (less than 45 minutes).

CONNECTIVITY

IoT PRIMERLINK standard.
 Management of laundries: OPL and COIN.
 Remote payment (self-service).

EFFICIENCY

Improved airflow system.
 Axial air flow.
 Large debris filter as a drawer.
 Efficient design.

ROBUSTNESS

Outer casing in grey Skinplate (BASIC model: white lacquered panels).
 Robust aluminium big door.
 Industrial fan and powerful airflow.
 Sturdy construction of the dryer structure and panels.

OTHERS

Galvanized drum.
 Electric and gas heated models.
 Grey skinplate panels.
 CE approved product

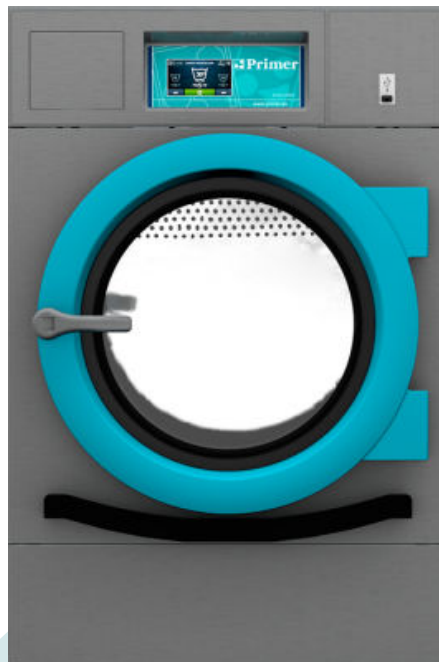

OPTIONS

- License IoT - PrimerLink
- Plinth for better ergonomics in skinplate
- Plinth for better ergonomics in stainless steel
- Drum stainless steel AISI 304
- Outer casing stainless steel AISI 430
- Reverse door opening
- Control panel mounted below (stacked dryer)
- Tropicalized model: protected board (T2)
- SMART DRY humidity control (T2)
- Fire extinguisher (T2)
- Order in complete container + compact packing
- 400V III / 230 I / III 60 Hz
- 440-480V III 50/60 Hz no N (maritime)
- NG gas option (Natural)
- Several payment systems for self-service

CAPACITY & DRUM		UNIT.	DP-8 T2
Capacity 1/18		Kg	8,9
		lb	19,6
Capacity 1/20		Kg	8
		lb	17,6
Ø Drum		mm	590
		inch	23,23
Drum length		mm	585
		inch	23,03
Drum volume		l	160
		cu ft	5,65
Ø Door hole		mm	480
		inch	18,90
Door center height		mm	554
		inch	21,81
Height from floor to bottom of door		mm	250
		inch	9,84
ELECTRIC HEATING			
Evaporation capacity		L/h	5,3
		US gallon/h	1,40
Hourly output		Kg/h	10,6
		lb/h	23,4
Installed heating power		kW	6,75 (1)
Installed electrical power		kW	7,17 (1)
Drum motor power		kW	0,37 (2)
GAS HEATING			
Evaporation capacity (gas model)		L/h	5,3
		US gallon/h	1,400
Hourly output (gas model)		Kg/h	10,6
		lb/h	23,4
Installed gas heating power		kcal/h	5761
		Btu/h	22861,3
Installed gas heating power		kW	6,70
Installed electrical power		kW	0,42
Instant propane gas consumption (G31)		Kg/h	0,57
		lb/h	1,26
Instant natural gas consumption (G20)		m ³ /h	0,71
		cfm	0,42
Ø Gas inlet		BSPP ISO 228-1	1/2"
THERMAL OIL HEATING			
Installed heating power		kW	-
Installed electrical power		kW	-
Fluid consumption (T max 175°C)		m ³ /h	-
Thermal oil connection		BSP	-
VENTILATION			
Fan motor power		kW	0,37(2)
Nominal air flow rate		m ³ /h	300
		cfm	176,57
Ø Fume exhaust		mm	100
Ø Fume exhaust		inch	3,94
HEAT EMISSION			
Maximum total heat emission		kW	0,45
		Btu/h	1536,4
Max. front heat emission		kW	0,32
		Btu/h	1075,5
CONNECTIONS			
Tension 230V - I + N + T		Nº x mm ² / A	E 3 x 10 / 40A G 3 x 1,5 / 10A



Tension 230V - III + T	Nº x mm ² / A	4 x 4 / 25A	3 x 1,5 / 10A (3)
Tension 400V - III + N + T	Nº x mm ² / A	5 x 2,5 / 16A	3 x 1,5 / 10A (4)
NET DIMENSIONS / D. WITH PACKING			
Net / gross width	mm	680 / 710	
	inch	26,77 / 27,95	
Net / gross depth	mm	722 / 832	
	inch	28,43 / 32,76	
Net height / gross height without heating	mm	1.056 / 1.141	
	inch	41,57 / 44,92	
Net / gross weight	Kg	89 / 100,5	
	lb	196,21 / 221,56	
OTHERS			
Sound level	dB	62	

- (1) Configurable via a terminal block system.
- (2) It's a single motor for both the drum and fan.
- (3) Connect two phases and ground.
- (4) Connect phase, neutral, and ground.

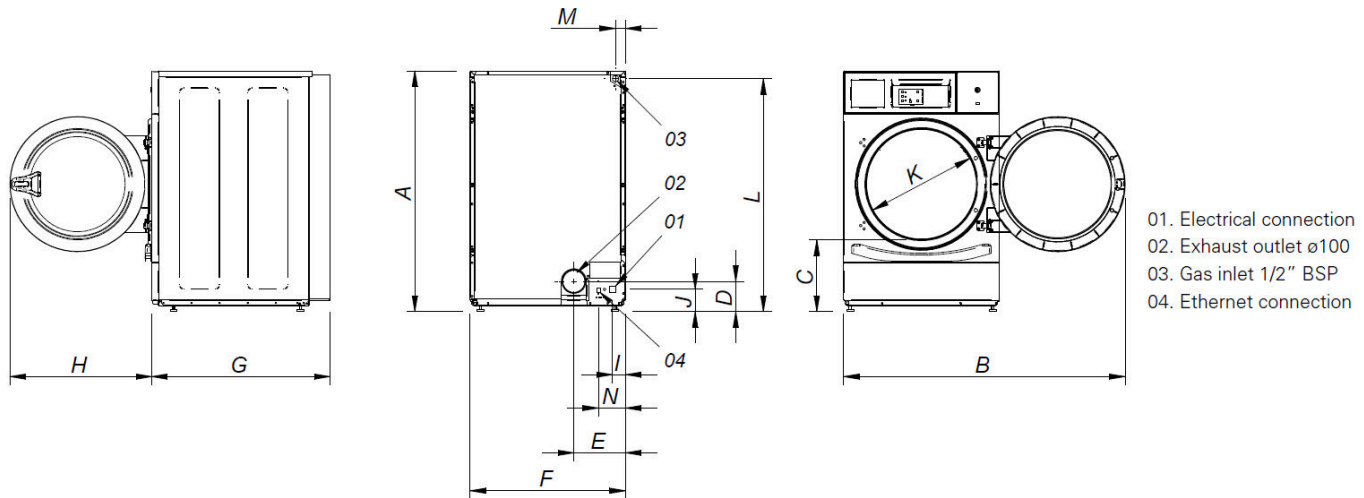

	A	B	C	D	E	F	G	H	I	J	K	L	M	N
DP-8 T2	1056	1227	320	140	226	680	722	615	57	91	480	1015	50	118
DP-10 T2	1056	1227	320	140	226	680	775	615	57	91	480	1015	50	118