



T2 CONTROL

User friendly and totally programmable 7" T2.
 USB Connection.
 Online platform free of charge for programming, telemetry, data analysis...thanks to the IoT.
 Videos on display (ads, instructions, etc.).
 37 languages.

OUTSTANDING FEATURES

Reversing drum action as standard.
 Stainless steel drum as standard.
 Frequency inverter as standard.

EFFICIENCY

DUAL AIRFLOW: Optimized system of mixed airflow.
 Big fluff filter.

CONNECTIVITY

IoT - PRIMERLINK standard.
 Managemnt of laundries: OPL and COIN.
 Remote payment (self-service) on models from 11 to 35 kg.

VERSATILITY

Make to order: customisation.
 Wet Cleaning.
 OPL > Multivending - Standard OPL model easily trasformable to coin laundry uses (11-35 kg).

ERGONOMICS

Drawer as fluff filter, stainless steel mesh.
 Biggest door diameters.
 Opening sense of door adjustable on site.

EASY MAINTENANCE

Hinged control panel: easy and ergonomic access.
 Technical menu: statistics for technicians.
 Easy access to parts for reparability.

OTHERS

Grey skinplate outer casing, stainless steel look.
 EFFICIENT DRUM: the new drum with stamped holes.
 COOL DOWN: anti-wrinkle at the end of the cycle.
 Heating options: electric, gas and steam.
 CE approved.

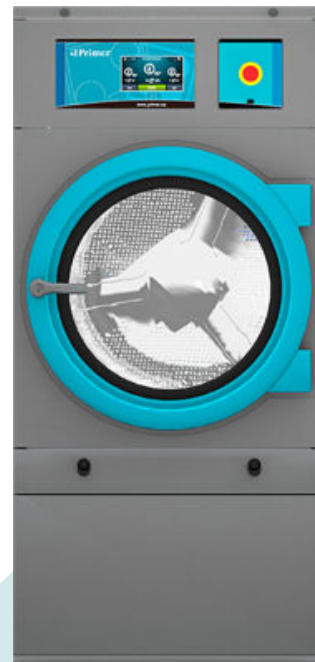

OPTIONS

- License IoT - PrimerLink
- Humidity control SMART DRY
- Double doorglass DO-11/14/18/22
- Fire extinguisher DO-11/14/18
- Opposite door opening DO-11 to 35
- Tropicalized model
- Perfume dosage
- Back panel with air filter DO-11 to 35
- Fluff filter with grid 0/6 mm (standard is 0/3 mm)
- Fluff filter with grid 1/2 mm (standard is 0/3 mm)
- Stainless steel front and side panels DO-11
- Front panel in stainless steel DO-11/14/18
- Steam battery in stainless steel DO-11/ 14/ 18
- Low pressure steam battery DO-11/14/18
- Maritime wooden packing DO-11
- NG gas option (Natural)
- 400 V III N 60 Hz DO-11 to 35
- 220 V III 50 Hz DO-11/14/18 E
- 220 V III 50 Hz DO-22/28/35 E
- 220 V III 60 Hz DO-11/14/18 E
- 220 V III 60 Hz DO-11 to 35 G/S
- 220 V I N 50 Hz DO-11 E
- 440/480 V III 60 Hz DO-11/14/18
- Several payment systems for self-service

CAPACITY & DRUM	UNIT.	DO-11 T2
Capacity 1/18	Kg	11,7
	lb	25,7
Capacity 1/20	Kg	10,5
	lb	23,1
Ø Drum	mm	750
	inch	29,53
Drum length	mm	475
	inch	18,70
Drum volume	l	210
	cu ft	7,41
Ø Door hole	mm	574
	inch	22,60
Door center height	mm	976
	inch	38,43
Height from floor to bottom of door	mm	618
	inch	24,33
ELECTRIC HEATING		
Evaporation capacity	L/h	9,3
	US gallon/h	2,46
Hourly output	Kg/h	20,3
	lb/h	44,8
Installed heating power	kW	12
Installed electrical power	kW	12,67
Drum motor power	kW	0,37
GAS HEATING		
Evaporation capacity (gas model)	L/h	14,5
	US gallon/h	3,830
Hourly output (gas model)	Kg/h	28,6
	lb/h	63,1
Installed gas heating power	kcal/h	17638
	Btu/h	70000
Installed gas heating power	kW	20,51
Installed electrical power	kW	0,67
Instant propane gas consumption (G31)	Kg/h	1,76
	lb/h	3,88
Instant natural gas consumption (G20)	m ³ /h	2,17
	cfm	1,28
Ø Gas inlet	BSPP ISO 228-1	1/2"
STEAM HEATING		
Installed steam heating power	kW	30
	Btu/h	102364
Installed electrical power	kW	0,67
Steam consumption (8 barG) - Standard	kg/h	53
Steam consumption (116 psiG)	lb/h	63,8
Steam pressure	barG	6 - 9
	psiG	87 - 130,5
Standard steam inlet - outlet	BSPT- ISO7.1	3/4"
Standard steam inlet - outlet	NPT ANSI B1.20.1 Tapered	3/4"
Steam consumption (5 barG) - Low Pressure	kg/h	57
Steam consumption (72,5 psiG) - Low Pressure	lb/h	68,7
Steam pressure (low pressure)	barG	3 - 6
	psiG	43,5 - 87
Low pressure steam inlet - outlet	BSPT- ISO7.1	1"
THERMAL OIL HEATING		
Installed heating power	kW	-
Installed electrical power	kW	-
Fluid consumption (T max 175°C)	m ³ /h	-



Thermal oil connection	BSP	-	
VENTILATION			
Fan motor power	kW	0,25	
Nominal air flow rate	m ³ /h	850	
	cfm	500,29	
Ø Fume exhaust	mm	200	
Ø Fume exhaust	inch	7,87	
HEAT EMISSION			
Maximum total heat emission	kW	1,2	
	Btu/h	4097	
Max. front heat emission	kW	0,84	
	Btu/h	2867,9	
CONNECTIONS			
Tension 230V - I + N + T	Nº x mm ² / A	E	G / S
Tension 230V - III + T	Nº x mm ² / A	3 x 25 / 63A	3 x 1,5 / 16A
Tension 400V - III + N + T	Nº x mm ² / A	4 x 10 / 40A	3 x 1,5 / 16A
Tension 400V - III + N + T	Nº x mm ² / A	5 x 4 / 25A	3 x 1,5 / 16A
NET DIMENSIONS / D. WITH PACKING			
Net / gross width	mm	785 / 865	
	inch	30,91 / 34,06	
Net / gross depth	mm	855 / 940	
	inch	33,66 / 37,01	
Net height / gross height without heating	mm	1.694 / 1.840	
	inch	66,69 / 72,44	
Net / gross weight	Kg	172 / 180	
	lb	379,20 / 396,83	
OTHERS			
Sound level	dB	64	

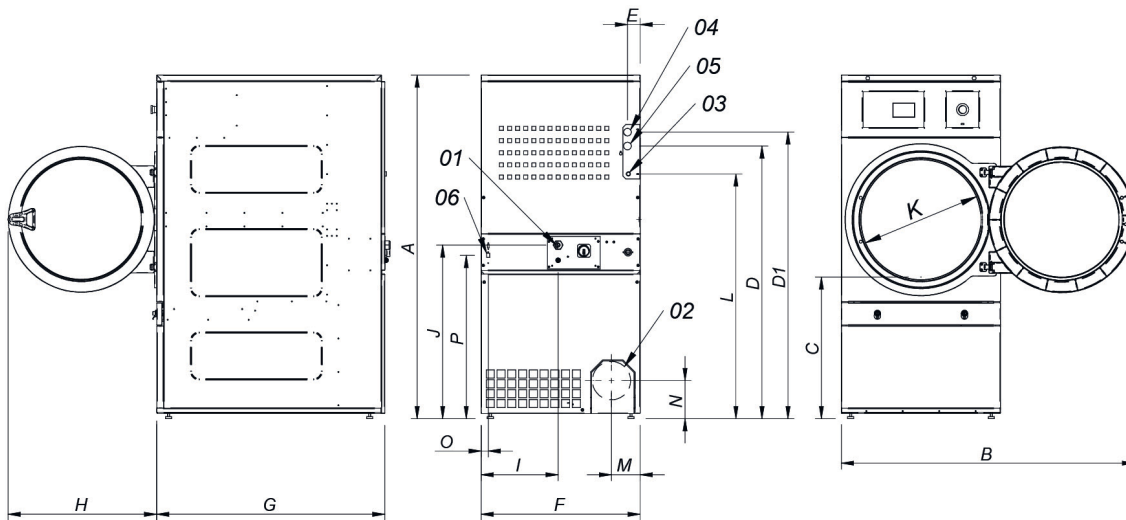

- 01. Power supply
- 02. Fumes output ø200
- 03. Gas inlet 1/2"
- 04. Steam inlet 3/4"
- 05. Condensate outlet 3/4"
- 06. Ethernet connection

* Measurement with legs mounted (30mm)

	A	B	C	D	D1	E	E1	F	G	H	I	J	K	L	M	N	O	P
DO-11	1694*	1447	689	1354	1422	68	68	785	855	735	380	870	575	1226	133	180	35	805
DO-14	1694*	1447	689	1354	1422	68	68	785	989	735	380	870	575	1226	133	180	35	805

