



### T2 CONTROL

User friendly and totally programmable 7" T2.  
 USB Connection.  
 Online platform free of charge for programming, telemetry, data analysis...thanks to the IoT.  
 Videos on display (ads, instructions, etc.).  
 37 languages.

### OUTSTANDING FEATURES

Reversing drum action as standard.  
 Stainless steel drum as standard.  
 Frequency inverter as standard.

### EFFICIENCY

DUAL AIRFLOW: Optimized system of mixed airflow.  
 Big fluff filter.

### CONNECTIVITY

**IoT - PRIMERLINK standard.**  
 Managemnt of laundries: OPL and COIN.  
 Remote payment (self-service) on models from 11 to 35 kg.

### VERSATILITY

Make to order: customisation.  
 Wet Cleaning.  
 OPL > Multivending - Standard OPL model easily trasformable to coin laundry uses (11-35 kg).

### ERGONOMICS

Drawer as fluff filter, stainless steel mesh.  
 Biggest door diameters.  
 Opening sense of door adjustable on site.

### EASY MAINTENANCE

Hinged control panel: easy and ergonomic access.  
 Technical menu: statistics for technicians.  
 Easy access to parts for reparability.

### OTHERS

Grey skinplate outer casing, stainless steel look.  
 EFFICIENT DRUM: the new drum with stamped holes.  
 COOL DOWN: anti-wrinkle at the end of the cycle.  
 Heating options: electric, gas and steam.  
 CE approved.

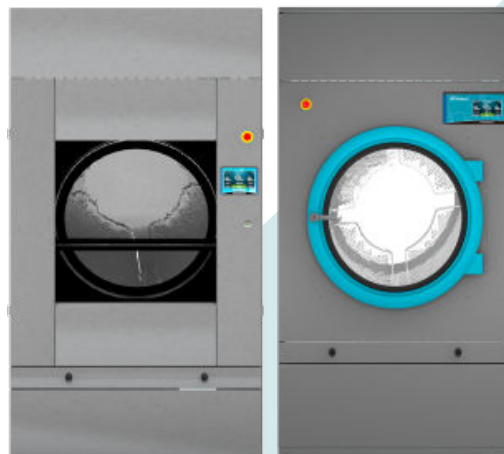

### OPTIONS

- License IoT - PrimerLink
- Automatic sliding door DO-45/60/80
- Manual sliding door DO-45/60/80 (no double glass)
- Frontal tilting kit for models DO-45/60/80
- Humidity control SMART DRY
- Double doorglass DO-28/35/45/60/80
- Fire extinguisher DO-45
- Opposite door opening DO-45/60/80
- Tropicalized model
- Perfume dosage
- Back panel with air filter DO-45/60/80
- Fluff filter with grid 0/6 mm (standard is 0/3 mm)
- Fluff filter with grid 1/2 mm (standard is 0/3 mm)
- Stainless steel front and side panels DO-45
- Front panel in stainless steel DO-45/60/80
- Low pressure steam battery DO-45/60/80
- Maritime wooden packing DO-45
- NG gas option (Natural)
- 400 V III N 60 Hz DO-45/60/80 E/S
- 400 V III N 60 Hz DO-45/60/80 G
- 220 V III 50 Hz DO-45/60/80 G
- 220 V III 60 Hz DO-45/60/80 E/S
- 220 V III 60 Hz DO-45/60/80 G
- 230 V III 50 Hz 45/60/80 E
- 230 V III 60 Hz 45/60/80 E
- 440/480 V III 60 Hz DO-45/60/80

CAPACITY & DRUM		UNIT.	DO-45 T2
Capacity 1/18		Kg	50
		lb	110,2
Capacity 1/20		Kg	45
		lb	99,2
Ø Drum		mm	1.225
		inch	48,23
Drum length		mm	760
		inch	29,92
Drum volume		l	900
		cu ft	31,78
Ø Door hole		mm	802
		inch	31,57
Door center height		mm	1.275
		inch	50,20
Height from floor to bottom of door		mm	813
		inch	31,99
ELECTRIC HEATING			
Evaporation capacity		L/h	40,2
		US gallon/h	10,6
Hourly output		Kg/h	80,4
		lb/h	177,2
Installed heating power		kW	54
Installed electrical power		kW	55,9
Drum motor power		kW	0,75
GAS HEATING			
Evaporation capacity (gas model)		L/h	42,5
		US gallon/h	11,227
Hourly output (gas model)		Kg/h	84,4
		lb/h	186,1
Installed gas heating power		kcal/h	51591
		Btu/h	204728,5
Installed gas heating power		kW	60
Installed electrical power		kW	1,9
Instant propane gas consumption (G31)		Kg/h	5,14
		lb/h	11,33
Instant natural gas consumption (G20)		m <sup>3</sup> /h	6,35
		cfm	3,74
Ø Gas inlet		BSPP ISO 228-1	3/4"
STEAM HEATING			
Installed steam heating power		kW	91
		Btu/h	310505
Installed electrical power		kW	1,9
Steam consumption (8 barG) - Standard		kg/h	121
Steam consumption (116 psiG)		lb/h	145,8
Steam pressure		barG	7 - 12
		psiG	101,5 - 174
Standard steam inlet - outlet		BSPT- ISO7.1	1"
Standard steam inlet - outlet		NPT ANSI B1.20.1 Tapered	1"
Steam consumption (5 barG) - Low Pressure		kg/h	142
Steam consumption (72,5 psiG) - Low Pressure		lb/h	171,1
Steam pressure (low pressure)		barG	4 - 7
		psiG	58 - 101,5
Low pressure steam inlet - outlet		BSPT- ISO7.1	1" 1/2
THERMAL OIL HEATING			
Installed heating power		kW	91
Installed electrical power		kW	1,9
Fluid consumption (T max 175°C)		m <sup>3</sup> /h	7



Thermal oil connection	BSP	1" 1/2	
<b>VENTILATION</b>			
Fan motor power	kW	1,1	
Nominal air flow rate	m <sup>3</sup> /h	3.000	
	cfm	1765,73	
Ø Fume exhaust	mm	300	
Ø Fume exhaust	inch	11,81	
<b>HEAT EMISSION</b>			
Maximum total heat emission	kW	16592,7	
	Btu/h	16592,7	
Max. front heat emission	kW	2,16	
	Btu/h	7374,5	
<b>CONNECTIONS</b>			
Tension 230V - I + N + T	Nº x mm <sup>2</sup> / A	-	-
Tension 230V - III + T	Nº x mm <sup>2</sup> / A	-	4 x 2,5 / 20A
Tension 400V - III + N + T	Nº x mm <sup>2</sup> / A	5 x 35 / 100A	5 x 2,5 / 20A
<b>NET DIMENSIONS / D. WITH PACKING</b>			
Net / gross width	mm	1.270 / 1.330	
	inch	50 / 52,36	
Net / gross depth	mm	1.106 / 1.185	
	inch	43,54 / 46,65	
Net height / gross height without heating	mm	2.380 /*2.200	
	inch	93,70 / *86,61	
Net / gross weight	Kg	395 / 430	
	lb	870,83 / 947,99	
<b>OTHERS</b>			
Sound level	dB	67	

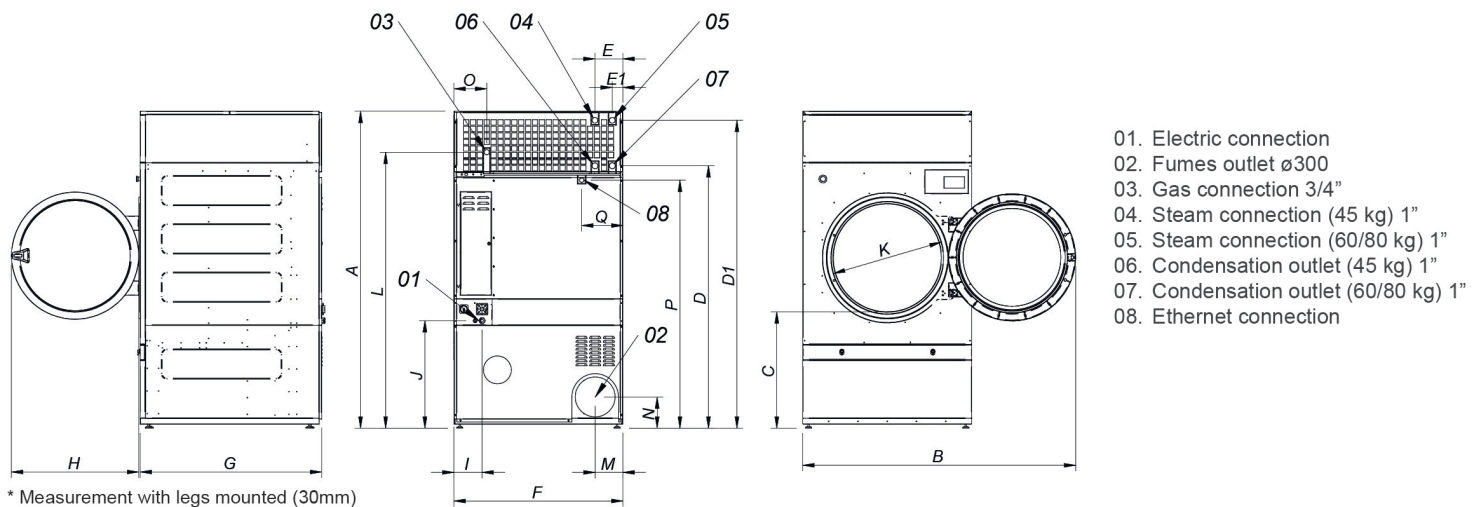

\* Measurement with legs mounted (30mm)

	A	B	C	D	D1	E	E1	F	G	H	I	J	K	L	M	N	O	P	Q
DO-45	2380*	2045	874	1981	2311	211	80	1270	1106	956	248	935	802	2088	214	240	244	160	1053
DO-60	2380*	2045	874	1981	2311	211	80	1270	1366	956	248	935	802	2088	214	240	244	160	1053
DO-80	2380*	2045	874	1981	2311	211	80	1270	1598	956	248	935	802	2088	214	240	244	160	1053

