



Primer

PN-140/25 Nomex EXCELLENCE Wall Ironers Ø250

ELECTRONIC CONTROL

PN-100/25, PN-120/25, PN-140/25, PN-200/25

- Digital screen: precise control of temperature.
- Preset ironing speeds, not adjustable.

PN-140/25, PN-200/25 EXCELLENCE

- Simple and user friendly with an **automatic mode**: automatic management of ironing speed according to the selected temperature.
- Digital speed and temperature display.

EFFICIENCY

Acoustic comfort: 65 dB max.

Minimum space requirement: space saving, suitable for small spaces.

Ideal for processing small quantity of flat linen in facilities like restaurants, guest rooms, hostels.

ROBUSTNESS

Nomex quality coating: resistant to high temperatures (option, standard on EXCELLENCE).

Panels in grey Skinplate and stainless steel.

Wooden feeding board.

Industrial components, more durable.

OUTSTANDING FEATURES

Large roll contact area with the linen.

Roll lifting control by pedal or automatic roll lifting control by foot cell detection.

Two available models:

- **Standard**: roll with cotton polyester coating.
- **Nomex**: roll with Nomex coating.

Modelos EXCELLENCE:

- Large roll contact area with the linen.
- Mode of operation identical to a flatwork ironer: no roll lifting, more ergonomic.
- Models equipped with Nomex belts, suction and variable speed inverter, more productivity.
- Adjustable speed and temperature.

EASY MAINTENANCE

Easy installation : requires only an electrical connection.

Easy access on both sides for maintenance.

Quick and easy dismantling of bearings.

OTHERS

Front feeding and return.

Roll Ø 250 mm.

Working widths: 1.000, 1.200, 1.400 and 2.000 mm.

Electric heating.

CE certification.

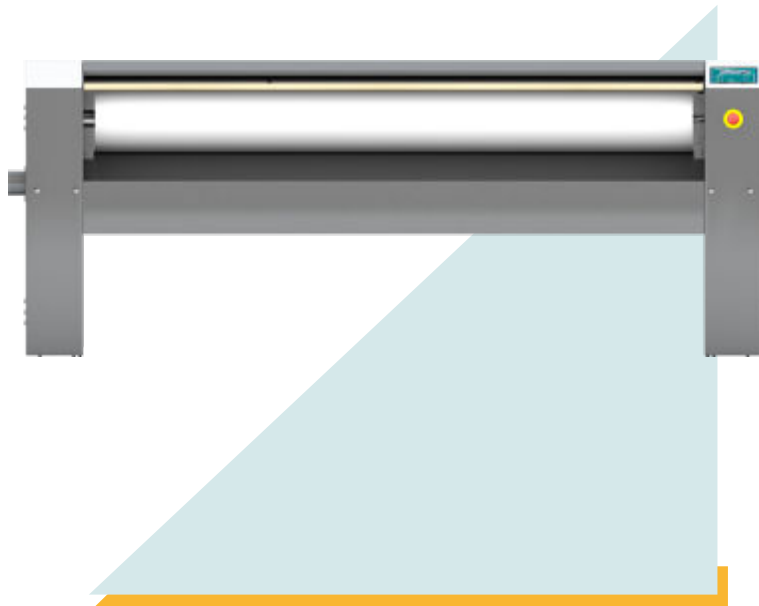

OPTIONS

- 230 V I N 50 Hz (except mod. 200 EXCELLENCE)
- 400 N T 60 Hz
- 440 V III 60 Hz No N (maritime)

GENERAL DETAILS

Theoretical production: 20-25 humidity	Kg/h	40
	Lb/h	88,18
Roll Ø	mm	250
	inch	9,84
Working width	mm	1.400
	inch	55,12
Working speed	m/min	1.5-6
	ft/mn	4,9 - 19,6
Electronic control	-	YES
Chest motion	-	NO

POWER

Heating power	Kw	7
Roll motor power	Kw	0.18
Fan motor power	Kw	0.12
Total electric power	Kw	7.3

CONNEXIONS

Tension 230 V I + N + T	n° x mm ² /A	-
	n° x AWG/A	-
Tension 230 V III + T	n° x mm ² /A	4 x 6 / 20A
	n° x AWG/A	4 x 9 / 20A
Tension 400 V III + N + T	n° x mm ² /A	5 x 4 / 16A
	n° x AWG/A	5 x 11 / 16A

DIMENSIONS

Net / gross width	mm	1.862 / 1.890
	inch	73,31 / 73,31
Net / gross depth	mm	484 / 540
	inch	19,06 / 21,26
Net / gross height	mm	985 / 1.130
	inch	38,78 / 44,49
Net / gross weight gross	Kg	134 / 154
	Lb	295,42 / 339,51
Net / gross volume gross	m ³	0,89 / 1,15
	ft ³	31,43 / 40,61

OTHERS

No. Fume outlet	Nº	1
Ø Fume outlet	mm	80
	inch	3,15
Air flow	m ³ /h	500
	cfm	294,29
Noise Level	dB	60

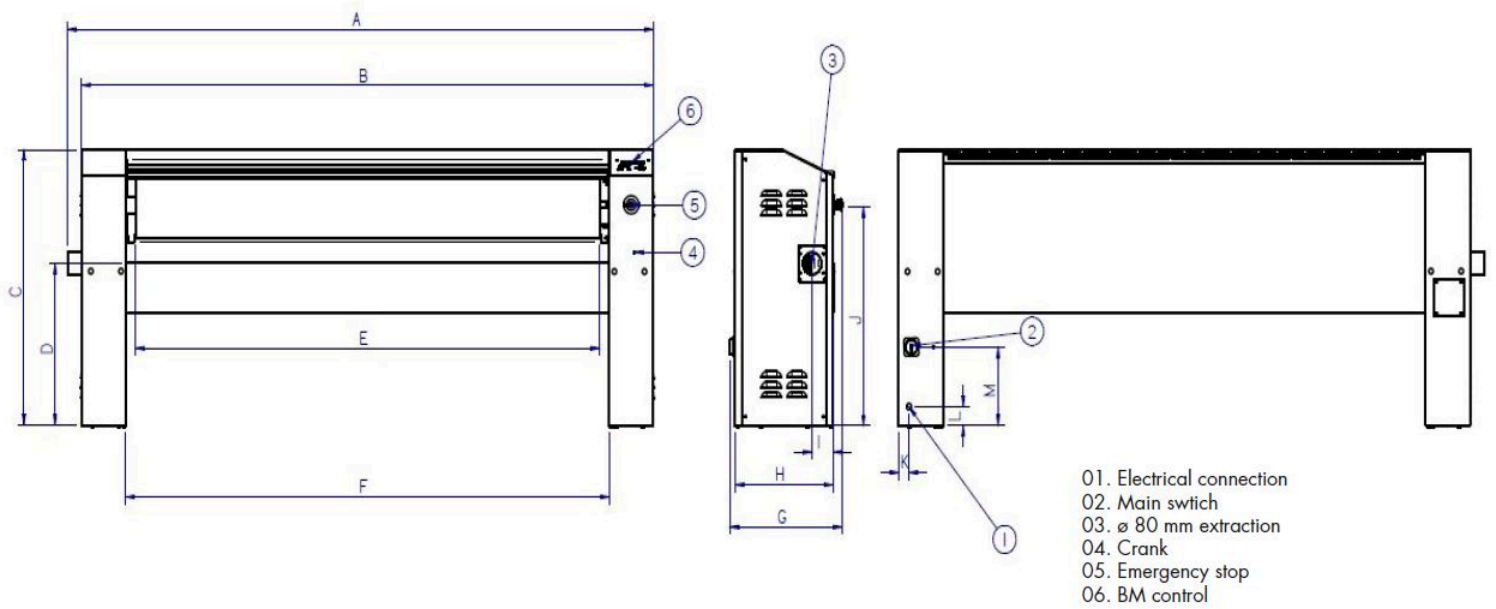

	A	B	C	D	E	F	G	H	I	J	K	L	M
PN-140/25 EXCELLENCE	1.922	1.862	985	610	1.400	1.480	484	423	91	791	45	75	287
PN-200/25 EXCELLENCE	2.522	2.462	985	610	2.000	2.080	484	423	91	791	45	75	287