



Primer

DL-18 P BASIC dryers

P CONTROL

Push buttons to control temperature and time.

OUTSTANDING FEATURES

Reversing drum action as standard.
Galvanized drum as standard.
Frequency inverter as standard.

EFFICIENCY

Big fluff filter.

VERSATILITY

Make to order - customisation.
OPL > Multivending - Standard OPL model easily transformable to coin laundry uses.

ERGONOMICS

Biggest door diameters.
Opening sense of door adjustable on site.

EASY MAINTENANCE

Hinged control panel: easy and ergonomic access.
Technical menu: statistics for technicians and maintenance with external console (with console option).
Easy to access to components.

OTHERS

White painted panels.
COOL DOWN - anti-wrinkle at the end of the cycle.
Heating options: electric or gas.
CE approved

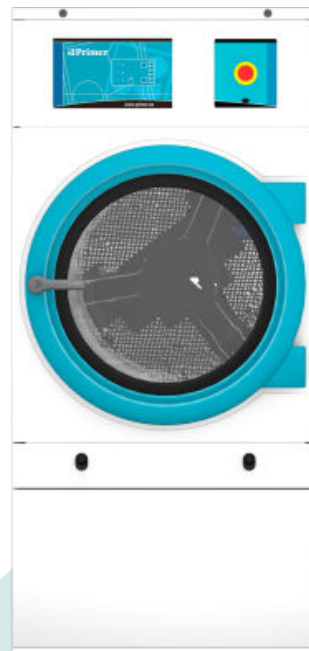

OPTIONS

- Opposite door opening 11 to 35
- Back panel with air filter 11 to 35
- NG gas option (Natural) for DL
- Display for P programmer
- 400 V III N 60 Hz
- 230 V III 50 Hz DL-11/14/18 E
- 230 V III 60 Hz DL-11/14/18 E
- 230 V III 60 Hz DL-11 to 35 G/S
- 440/480 V III 60 Hz DL-11/14/18
- Reduced power (12kw instead of 18kw) for elect. heated DL-14/18
- Maritime wooden packing DL-14/18
- Several payment systems for self-service

CAPACITY & DRUM		UNIT.	DL-18 P
Capacity 1/18		Kg	18,3
		lb	40,4
Capacity 1/20		Kg	16,5
		lb	36,3
Ø Drum		mm	750
		inch	29,53
Drum length		mm	746
		inch	29,37
Drum volume		l	330
		cu ft	11,64
Ø Door hole		mm	574
		inch	22,60
Door center height		mm	976
		inch	38,43
Height from floor to bottom of door		mm	618
		inch	24,33
ELECTRIC HEATING			
Evaporation capacity		L/h	14,10
		US gallon/h	3,72
Hourly output		Kg/h	28,3
		lb/h	62,4
Installed heating power		kW	18
Installed electrical power		kW	18,67
Drum motor power		kW	0,37
GAS HEATING			
Evaporation capacity (gas model)		L/h	16,30
		US gallon/h	4,306
Hourly output (gas model)		Kg/h	31,9
		lb/h	70,3
Installed gas heating power		kcal/h	17638
		Btu/h	70000
Installed gas heating power		kW	20,51
Installed electrical power		kW	0,67
Instant propane gas consumption (G31)		Kg/h	1,76
		lb/h	3,88
Instant natural gas consumption (G20)		m ³ /h	2,17
		cfm	1,28
Ø Gas inlet		BSPP ISO 228-1	1/2"
STEAM HEATING			
Installed steam heating power		kW	30
		Btu/h	102364
Installed electrical power		kW	0,67
Steam consumption (8 barG) - Standard		kg/h	53
Steam consumption (116 psiG)		lb/h	63,8
Steam pressure		barG	6 - 9
		psiG	87 - 130,5
Standard steam inlet - outlet		BSPT- ISO7.1	3/4"
Standard steam inlet - outlet		NPT ANSI B1.20.1 Tapered	3/4"
Steam consumption (5 barG) - Low Pressure		kg/h	57
Steam consumption (72,5 psiG) - Low Pressure		lb/h	68,7
Steam pressure (low pressure)		barG	3 - 6
		psiG	43,5 - 91
Low pressure steam inlet - outlet		BSPT- ISO7.1	1"
THERMAL OIL HEATING			
Installed heating power		kW	-
Installed electrical power		kW	-
Fluid consumption (T max 175°C)		m ³ /h	-



Thermal oil connection	BSP	-	
VENTILATION			
Fan motor power	kW	0,25	
Nominal air flow rate	m ³ /h	850	
	cfm	500,29	
Ø Fume exhaust	mm	200	
Ø Fume exhaust	inch	7,87	
HEAT EMISSION			
Maximum total heat emission	kW	1,8	
	Btu/h	6145,5	
Max. front heat emission	kW	1,26	
	Btu/h	4301,8	
CONNECTIONS		E	G / S
Tension 230V - I + N + T	Nº x mm ² / A	-	3 x 1,5 / 16A
Tension 230V - III + T	Nº x mm ² / A	4 x 16 / 63A	3 x 1,5 / 16A
Tension 400V - III + N + T	Nº x mm ² / A	5 x 10 / 32A	3 x 1,5 / 16A
NET DIMENSIONS / D. WITH PACKING			
Net / gross width	mm	785 / 865	
	inch	30,91 / 34,06	
Net / gross depth	mm	1.125 / 1.210	
	inch	44,29 / 47,64	
Net height / gross height without heating	mm	1.694 / 1.840	
	inch	66,69 / 72,44	
Net / gross weight	Kg	187 / 200	
	lb	412,26 / 440,92	
OTHERS			
Sound level	dB	64	

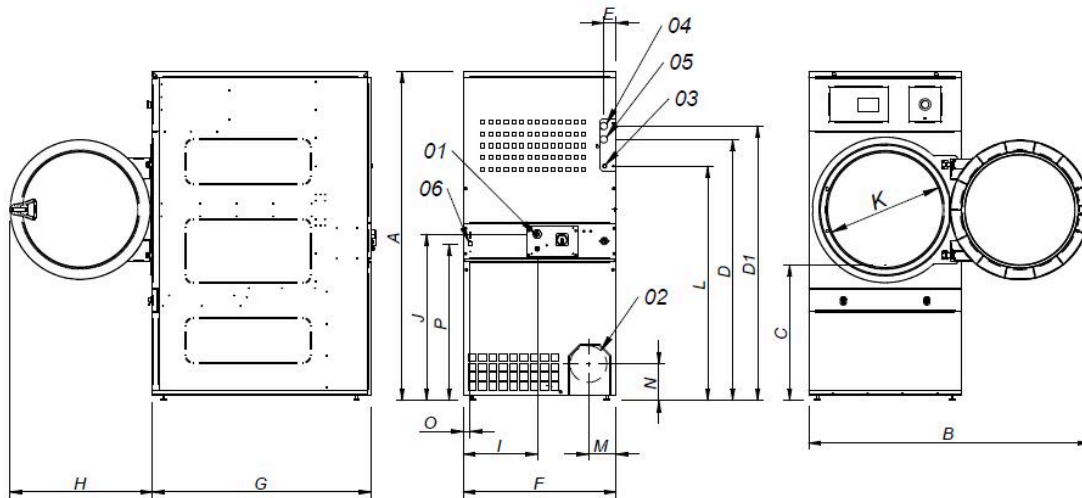

- 01 POWER SUPPLY
- 02 FUMES OUTPUT Ø200
- 03 GAS INLET 1/2"
- 04 STEAM INLET 3/4" (DL-18)
- 05 STEAM INLET 1" (DL-22)
- 06 CONDENSATE OUTLET 3/4" (DL-18)
- 07 CONDENSATE OUTLET 1" (DL-22)
- 08 ETHERNET CONNECTION (only available CONTROL T2 models)

* Measurement with legs mounted (30mm)

	A	B	C	D	D1	E	E1	F	G	H	I	J	K	L	M	N	O	P
DL - 18	1694*	1447	689	1354	1422	68	68	785	1125	735	380	870	575	1226	133	180	35	805
DL - 22	1812*	1552	743	1430	1532	112	55	890	1255	735	107	920	575	1344	238	180	37	860

