



# Primer

## DL-35 P

## BASIC dryers

### P CONTROL

Push buttons to control temperature and time.

### OUTSTANDING FEATURES

Reversing drum action as standard.  
Galvanized drum as standard.  
Frequency inverter as standard.

### EFFICIENCY

Big fluff filter.

### VERSATILITY

Make to order - customisation.  
OPL > Multivending - Standard OPL model easily transformable to coin laundry uses.

### ERGONOMICS

Biggest door diameters.  
Opening sense of door adjustable on site.

### EASY MAINTENANCE

Hinged control panel: easy and ergonomic access.  
Technical menu: statistics for technicians and maintenance with external console (with console option).  
Easy to access to components.

### OTHERS

White painted panels.  
COOL DOWN - anti-wrinkle at the end of the cycle.  
Heating options: electric or gas.  
CE approved



### OPTIONS

- Opposite door opening 11 to 35
- Back panel with air filter 11 to 35
- NG gas option (Natural) for DL
- Display for P programmer
- 400 V III N 60 Hz
- 230 V III 50 Hz DL-22/28/35
- 230 V III 60 Hz DL-22/28/35
- 230 V III 60 Hz DL-11 to 35 G/S
- 440/480 V III 60 Hz DL-22/28/35
- Maritime wooden packing DL-35
- Several payment systems for self-service

CAPACITY & DRUM		UNIT.	DL-35 P
Capacity 1/18		Kg	36,7
		lb	80,8
Capacity 1/20		Kg	33
		lb	72,8
Ø Drum		mm	947
		inch	37,28
Drum length		mm	936
		inch	36,85
Drum volume		l	660
		cu ft	23,30
Ø Door hole		mm	802
		inch	31,57
Door center height		mm	1.040
		inch	40,94
Height from floor to bottom of door		mm	578
		inch	22,74
ELECTRIC HEATING			
Evaporation capacity		L/h	31,50
		US gallon/h	8,2
Hourly output		Kg/h	60
		lb/h	132,3
Installed heating power		kW	36
Installed electrical power		kW	37,15
Drum motor power		kW	0,55
GAS HEATING			
Evaporation capacity (gas model)		L/h	32,1
		US gallon/h	8,480
Hourly output (gas model)		Kg/h	63,9
		lb/h	140,9
Installed gas heating power		kcal/h	35276
		Btu/h	139986,5
Installed gas heating power		kW	41
Installed electrical power		kW	1,15
Instant propane gas consumption (G31)		Kg/h	3,51
		lb/h	7,74
Instant natural gas consumption (G20)		m <sup>3</sup> /h	4,34
		cfm	2,55
Ø Gas inlet		BSPP ISO 228-1	1/2"
STEAM HEATING			
Installed steam heating power		kW	50,10
		Btu/h	170948
Installed electrical power		kW	1,15
Steam consumption (8 barG) - Standard		kg/h	89
Steam consumption (116 psiG)		lb/h	107,2
Steam pressure		barG	6 - 9
		psiG	87 - 130,5
Standard steam inlet - outlet		BSPT- ISO7.1	1"
Standard steam inlet - outlet		NPT ANSI B1.20.1 Tapered	1"
Steam consumption (5 barG) - Low Pressure		kg/h	93
Steam consumption (72,5 psiG) - Low Pressure		lb/h	112
Steam pressure (low pressure)		barG	3 - 6
		psiG	43,5 - 97
Low pressure steam inlet - outlet		BSPT- ISO7.1	1" 1/2
THERMAL OIL HEATING			
Installed heating power		kW	-
Installed electrical power		kW	-
Fluid consumption (T max 175°C)		m <sup>3</sup> /h	-



Thermal oil connection	BSP	-	
<b>VENTILATION</b>			
Fan motor power	kW	0,55	
Nominal air flow rate	m <sup>3</sup> /h	1.200	
	cfm	706,29	
Ø Fume exhaust	mm	200	
Ø Fume exhaust	inch	7,87	
<b>HEAT EMISSION</b>			
Maximum total heat emission	kW	3,6	
	Btu/h	12290,9	
Max. front heat emission	kW	2,52	
	Btu/h	8603,6	
<b>CONNECTIONS</b>			
Tension 230V - I + N + T	Nº x mm <sup>2</sup> / A	E	G / S
Tension 230V - III + T	Nº x mm <sup>2</sup> / A	4 x 50 / 125A	3 x 1,5 / 16A
Tension 400V - III + N + T	Nº x mm <sup>2</sup> / A	5 x 16 / 63A	3 x 1,5 / 16A
<b>NET DIMENSIONS / D. WITH PACKING</b>			
Net / gross width	mm	985 / 1.065	
	inch	38,78 / 41,93	
Net / gross depth	mm	1.210 / 1.310	
	inch	47,64 / 51,57	
Net height / gross height without heating	mm	1.975 / 2.080	
	inch	77,76 / 81,89	
Net / gross weight	Kg	260 / 285	
	lb	573,20 / 628,32	
<b>OTHERS</b>			
Sound level	dB	65	

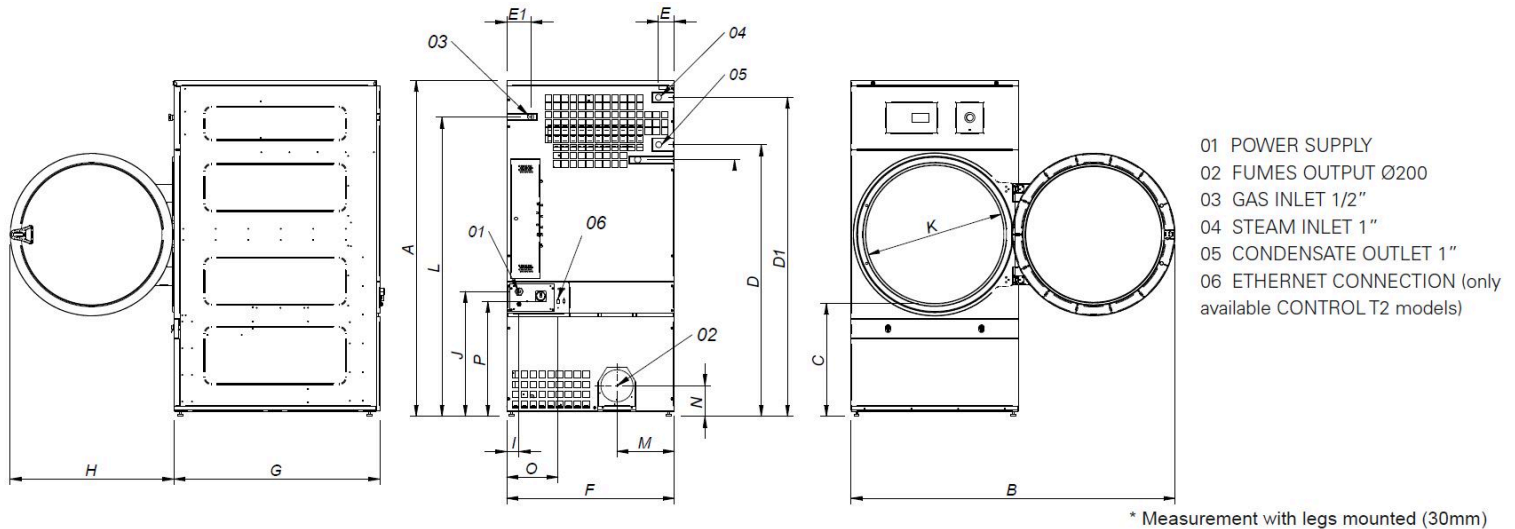

	A	B	C	D	D1	E	E1	F	G	H	I	J	K	L	M	N	O	P
DL - 28	1975*	1910	660	1590	1875	102	130	985	1054	970	70	730	802	1760	337	178	301	676
DL - 35	1975*	1910	660	1590	1875	102	130	985	1210	970	70	730	802	1760	337	178	301	676

