



# Primer

## DS-11 P

## STANDARD dryers

### P CONTROL

Push buttons to control temperature and time.

### OUTSTANDING FEATURES

Reversing drum action as standard.  
Stainless steel drum as standard.  
Frequency inverter as standard.

### EFFICIENCY

DUAL AIRFLOW - Optimized system of mixed air flow.  
Big fluff filter.

### VERSATILITY

Make to order: customisation.  
OPL > Coin laundry - Standard OPL model easily trasformable to coin laundry uses.

### ERGONOMICS

Drawer as fluff filter, stainless steel mesh.  
Biggest door diameters.  
Opening sense of door adjustable on site (models without sliding door).

### EASY MAINTENANCE

Hinged control panel: easy and ergonomic access.  
Technical menu: statistics for technicians and maintenance with external console (with console option).  
Easy to access to components

### OTHERS

Grey Skinplate outer casing, stainless steel look.  
EFFICIENT DRUM: the new drum with stamped holes.  
COOL DOWN: anti-wrinkle at the end of the cycle.  
Heating options: electric, gas and steam.  
CE approved.

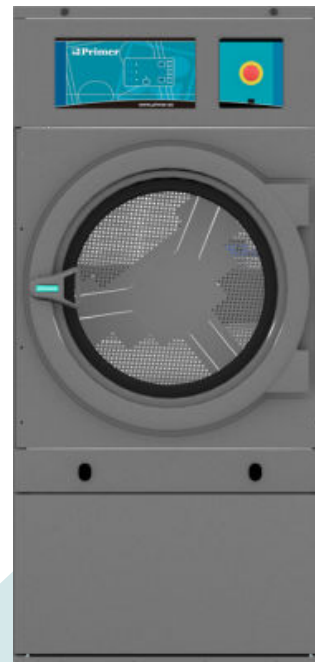

### OPTIONS

- Double doorglass DS-11/14/18/22
- Opposite door opening DS-11 to 35
- P programmer display for DS-11 to 35
- Back panel with air filter DS-11 to 35
- Fluff filter with grid 0/6 mm (standard is 0/3 mm)
- Fluff filter with grid 1/2 mm (standard is 0/3 mm)
- Stainless steel AISI 304 outer casing for DS-11
- Stainless steel AISI 304 front panel for DS-11/14/18
- Steam battery in stainless steel DS- 11/14/18
- Low pressure steam battery DS-11/14/18
- NG gas option (Natural)
- Maritime wooden packing DS-11
- 400V 3N 60 Hz DS-11 to 35
- 230V 3~ 50Hz DS-11/14/18 E
- 230V 3~ 60 Hz DS-11/14/18 E
- 230V 3~ 60 Hz DS-11 to 35 G/S
- 230V 1N 50 Hz DS-11 E
- 440/480V 3~ 60 Hz DS-11/14/18
- Several payment systems for self-service

CAPACITY & DRUM		UNIT.	DS-11 P
Capacity 1/18		Kg	11,7
		lb	25,7
Capacity 1/20		Kg	10,5
		lb	23,1
Ø Drum		mm	750
		inch	29,53
Drum length		mm	475
		inch	18,70
Drum volume		l	210
		cu ft	7,41
Ø Door hole		mm	574
		inch	22,60
Door center height		mm	976
		inch	38,4
Height from floor to bottom of door		mm	618
		inch	24,33
ELECTRIC HEATING			
Evaporation capacity		L/h	9,3
		US gallon/h	2,46
Hourly output		Kg/h	20,3
		lb/h	44,8
Installed heating power		kW	12
Installed electrical power		kW	12,67
GAS HEATING			
Evaporation capacity (gas model)		L/h	14,5
		US gallon/h	3,830
Hourly output (gas model)		Kg/h	29
		lb/h	63,93
Installed gas heating power		kcal/h	17627
		Btu/h	69996
Installed gas heating power		kW	20,5
Installed electrical power		kW	0,67
Instant propane gas consumption (G31)		Kg/h	1,76
		lb/h	3,88
Instant natural gas consumption (G20)		m <sup>3</sup> /h	2,17
		cfm	1,28
Ø Gas inlet		BSPP ISO 228-1	1/2"
STEAM HEATING			
Installed steam heating power		kW	30
		Btu/h	102364
Installed electrical power		kW	0,67
Steam consumption (8 barG) - Standard		kg/h	53
Steam consumption (116 psiG)		lb/h	63,8
Steam pressure		barG	6 - 9
		psiG	87 - 130,5
Standard steam inlet - outlet		BSPT- ISO7.1	3/4"
Standard steam inlet - outlet		NPT ANSI B1.20.1 Tapered	3/4"
Steam consumption (5 barG) - Low Pressure		kg/h	57
Steam consumption (72,5 psiG) - Low Pressure		lb/h	68,7
Steam pressure (low pressure)		barG	3 - 6
		psiG	43,5 - 87
Low pressure steam inlet - outlet		BSPT- ISO7.1	1"
THERMAL OIL HEATING			
Installed heating power		kW	-
Installed electrical power		kW	-
Fluid consumption (T max 175°C)		m <sup>3</sup> /h	-
Thermal oil connection		BSP	-



## POWER AND VENTILATION

Drum motor power	kW	0,37
Fan motor power	kW	0,25
Nominal air flow rate	m <sup>3</sup> /h	850
	cfm	500
Ø Fume exhaust	mm	200
Ø Fume exhaust	inch	7,87

## HEAT EMISSION

Maximum total heat emission	kW	1,2
	Btu/h	4097
Max. front heat emission	kW	0,8
	Btu/h	2868

## CONNECTIONS

		E	G / S
Tension 230V - I + N + T	Nº x mm <sup>2</sup> / A	3 x 25 / 63A	3 x 1,5 / 16A
Tension 230V - III + T	Nº x mm <sup>2</sup> / A	4 x 10 / 40A	3 x 1,5 / 16A
Tension 400V - III + N + T	Nº x mm <sup>2</sup> / A	5 x 4 / 25A	3 x 1,5 / 16A

## NET DIMENSIONS / D. WITH PACKING

Net / gross width	mm	785 / 865
	inch	30,9 / 34,1
Net / gross depth	mm	855 / 940
	inch	33,7 / 37
Net height / gross height without heating	mm	1.694 / 1.840
	inch	66,7 / 72,4
Net / gross weight	Kg	172 / 180
	lb	379 / 397

## OTHERS

Sound level	dB	64
-------------	----	----

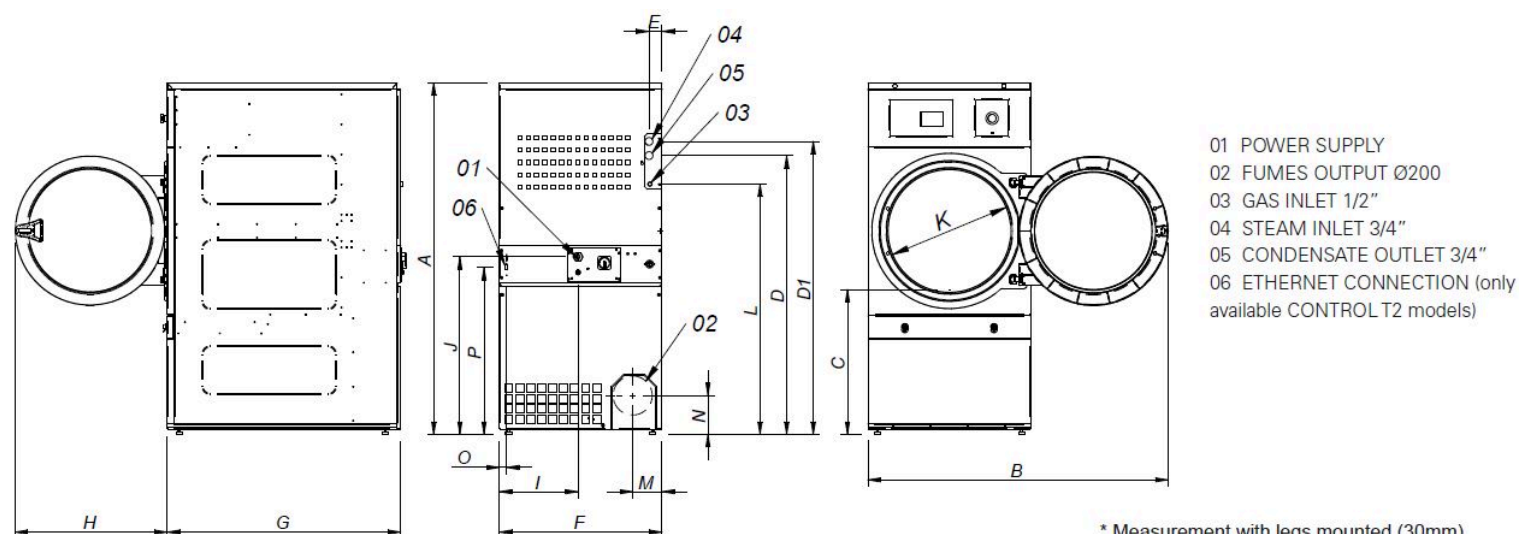

\* Measurement with legs mounted (30mm)

	A	B	C	D	D1	E	E1	F	G	H	I	J	K	L	M	N	O	P
DS-11P	1694*	1447	689	1354	1422	68	68	785	855	735	380	870	575	1226	133	180	35	805
DS-14P	1694*	1447	689	1354	1422	68	68	785	989	735	380	870	575	1226	133	180	35	805