



### VERSATILITY

OPL <> COIN: Standard models can be programmed as OPL or coin laundry version, central pay, etc.  
SINGLE <> STACKED: Models can be stacked on top of a washer or on another dryer.  
Control panels can be assembled between both drums for better ergonomics.  
Ideal for multiple solutions: hotels, hostels, campings, coin laundries, facility services (mops), gyms, etc.

### OUTSTANDING FEATURES

**P PROGRAMMER:** selection of time and temperature, user friendly and versatile (OPL or coin laundry version).  
Reduced drying times (less than 45 minutes).  
6,75 kw heating, option 4,5 kW (4,5 kW in Essential Model).

### EFFICIENCY

Optimised airflow.  
Wide fluff filter as drawer.  
Efficient design.

### ROBUSTNESS

Outer casing in grey skinplate.  
Robust aluminium big door.  
Drawer as fluff filter (not in the door but as a specific drawer).  
Industrial fan and powerful airflow.  
Sturdy construction of the dryer structure and panels.

### OTHERS

Galvanized drum.  
Electric and gas heated models.  
Grey skinplate panels.  
CE approved product

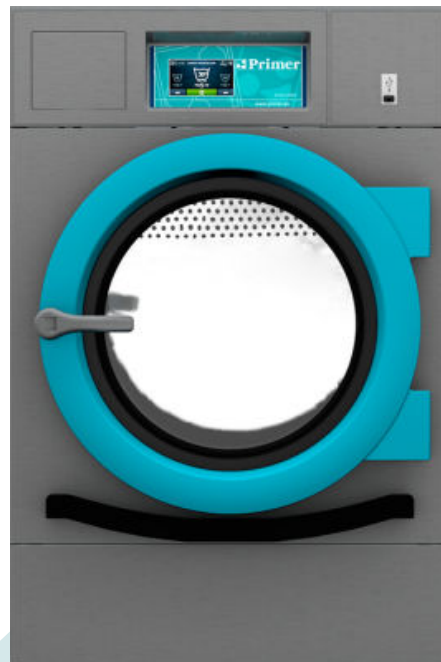

### OPTIONS

- Plinth for better ergonomics in skinplate
- Plinth for better ergonomics in stainless steel
- Drum stainless steel AISI 304
- Outer casing stainless steel AISI 430
- Reverse door opening
- Control panel mounted below (stacked dryer)
- Fire extinguisher (T2)
- Order in complete container + compact packing
- 400V III / 230 I / III 60 Hz
- 440-480V III 50/60 Hz no N (maritime)
- NG gas option (Natural)
- Several payment systems for self-service

CAPACITY & DRUM		UNIT.	DP-10 P	
Capacity 1/18		Kg	11,1	
		lb	24,5	
Capacity 1/20		Kg	10	
		lb	22	
Ø Drum		mm	590	
		inch	23,23	
Drum length		mm	690	
		inch	27,17	
Drum volume		l	200	
		cu ft	7,06	
Ø Door hole		mm	480	
		inch	18,90	
Door center height		mm	554	
		inch	21,81	
Height from floor to bottom of door		mm	250	
		inch	9,84	
ELECTRIC HEATING				
Evaporation capacity		L/h	6,35	
		US gallon/h	1,68	
Hourly output		Kg/h	12,5	
		lb/h	27,6	
Installed heating power		kW	6,75 (1)	
Installed electrical power		kW	7,17 (1)	
Drum motor power		kW	0,37 (2)	
GAS HEATING				
Evaporation capacity (gas model)		L/h	6,35	
		US gallon/h	1,677	
Hourly output (gas model)		Kg/h	12,5	
		lb/h	27,6	
Installed gas heating power		kcal/h	5761	
		Btu/h	22861,3	
Installed gas heating power		kW	6,70	
Installed electrical power		kW	0,42	
Instant propane gas consumption (G31)		Kg/h	0,57	
		lb/h	1,26	
Instant natural gas consumption (G20)		m <sup>3</sup> /h	0,71	
		cfm	0,42	
Ø Gas inlet		BSPP ISO 228-1	1/2"	
THERMAL OIL HEATING				
Installed heating power		kW	-	
Installed electrical power		kW	-	
Fluid consumption (T max 175°C)		m <sup>3</sup> /h	-	
Thermal oil connection		BSP	-	
VENTILATION				
Fan motor power		kW	0,37(2)	
Nominal air flow rate		m <sup>3</sup> /h	300	
		cfm	176,57	
Ø Fume exhaust		mm	100	
Ø Fume exhaust		inch	3,94	
HEAT EMISSION				
Maximum total heat emission		kW	0,45	
		Btu/h	1536,4	
Max. front heat emission		kW	0,32	
		Btu/h	1075,5	
CONNECTIONS				
Tension 230V - I + N + T		Nº x mm <sup>2</sup> / A	E 3 x 10 / 40A	G 3 x 1,5 / 10A



Tension 230V - III + T	Nº x mm <sup>2</sup> / A	4 x 4 / 25A	3 x 1,5 / 10A (3*)
Tension 400V - III + N + T	Nº x mm <sup>2</sup> / A	5 x 2,5 / 16A	3 x 1,5 / 10A (4*)
<b>NET DIMENSIONS / D. WITH PACKING</b>			
Net / gross width	mm	680 / 710	
	inch	26,77 / 27,95	
Net / gross depth	mm	775 / 832	
	inch	30,51 / 32,76	
Net height / gross height without heating	mm	1.056 / 1.141	
	inch	41,57 / 44,92	
Net / gross weight	Kg	92,6 / 104,1	
	lb	204,15 / 229,50	
<b>OTHERS</b>			
Sound level	dB	62	

- (1) Configurable via a terminal block system.  
(2) It's a single motor for both the drum and fan.  
(3\*) Connect two phases and ground.  
(4\*) Connect phase, neutral, and ground.

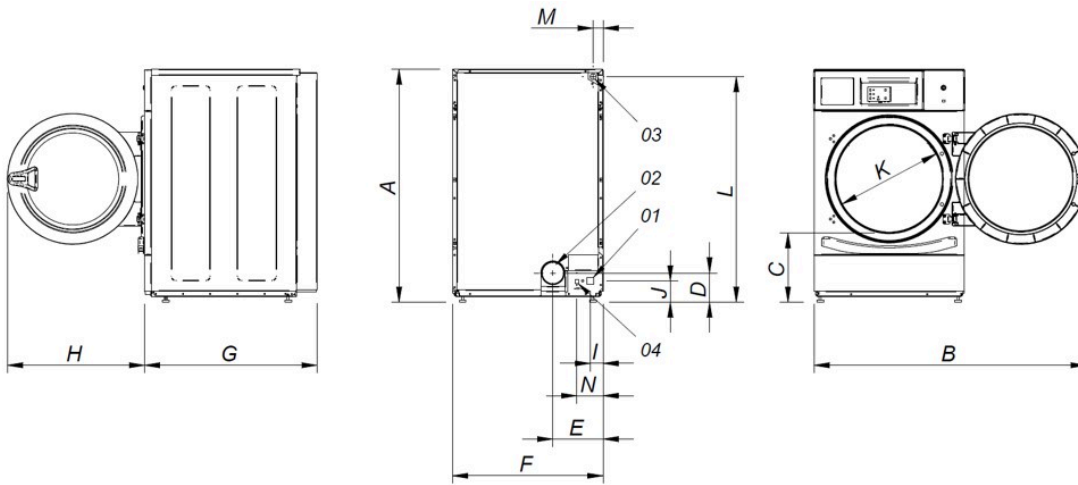

- 01 Power supply  
02 Fumes output Ø 100  
03 Gas inlet 1/2"  
04 Ethernet connection (only TOUCH control)

	A	B	C	D	E	F	G	H	I	J	K	L	M	N
DP-8	1.056	1.227	320	140	226	680	722	615	57	91	480	1.015	50	118
DP-10	1.056	1.227	320	140	226	680	775	615	57	91	480	1.015	50	118