



ELECTRONIC CONTROL

PN-100/25, PN-120/25, PN-140/25, PN-200/25

- Digital screen: precise control of temperature.
- Preset ironing speeds, not adjustable.

PN-140/25, PN-200/25 EXCELLENCE

- Simple and user friendly with an **automatic mode**: automatic management of ironing speed according to the selected temperature.
- Digital speed and temperature display.

EFFICIENCY

Acoustic comfort: 65 dB max.

Minimum space requirement: space saving, suitable for small spaces.

Ideal for processing small quantity of flat linen in facilities like restaurants, guest rooms, hostels.

ROBUSTNESS

Nomex quality coating: resistant to high temperatures (option, standard on EXCELLENCE).

Panels in grey Skinplate and stainless steel.

Wooden feeding board.

Industrial components, more durable.

OUTSTANDING FEATURES

Large roll contact area with the linen.

Roll lifting control by pedal or automatic roll lifting control by foot cell detection.

Two available models:

- **Standard**: roll with cotton polyester coating.
- **Nomex**: roll with Nomex coating.

Modelos EXCELLENCE:

- Large roll contact area with the linen.
- Mode of operation identical to a flatwork ironer: no roll lifting, more ergonomic.
- Models equipped with Nomex belts, suction and variable speed inverter, more productivity.
- Adjustable speed and temperature.

EASY MAINTENANCE

Easy installation : requires only an electrical connection.

Easy access on both sides for maintenance.

Quick and easy dismantling of bearings.

OTHERS

Front feeding and return.

Roll Ø 250 mm.

Working widths: 1.000, 1.200, 1.400 and 2.000 mm.

Electric heating.

CE certification.

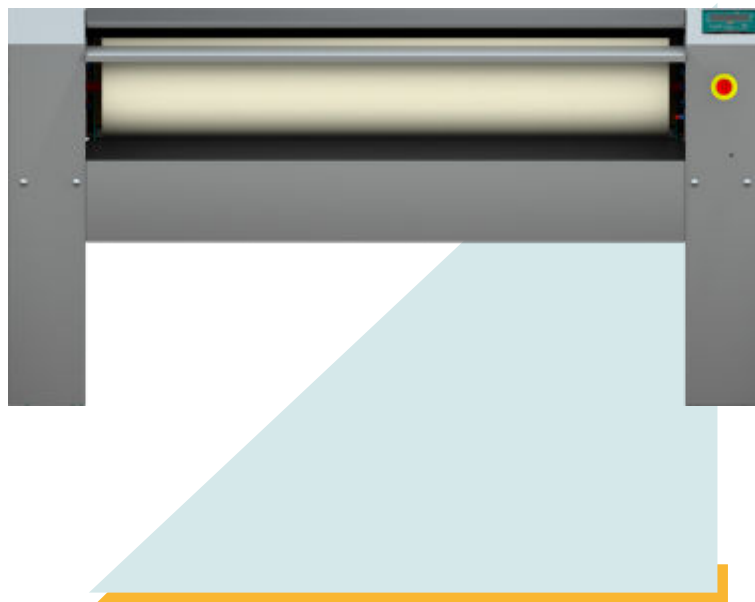

OPTIONS

- Pedal control instead of photocell (except mod. EXCELLENCE)
- 230 V I N 50 Hz (except mod. 200 EXCELLENCE)
- 400 N T 60 Hz
- 440 V III 60 Hz No N (maritime)

GENERAL DETAILS

Theoretical production: 20-25 humidity	Kg/h	27,50
	Lb/h	60,63
Roll Ø	mm	250
	inch	9,84
Working width	mm	1.200
	inch	47,24
Working speed	m/min	4.2
	ft/mn	13,77
Electronic control	-	YES
Chest motion	-	Automático

POWER

Heating power	Kw	6
Roll motor power	Kw	0,18
Total electric power	Kw	6,18

CONNEXIONS

Tension 230 V I + N + T	nº x mm²/A	3 x 6 / 32A
	nº x AWG/A	3 x 9 / 32A
Tension 230 V III + T	nº x mm²/A	4 x 4 / 20A
	nº x AWG/A	4 x 11 / 20A
Tension 400 V III + N + T	nº x mm²/A	5 x 2,5 / 10A
	nº x AWG/A	5 x 13 / 10A

DIMENSIONS

Net / gross width	mm	1.662 / 1.690
	inch	65,43 / 65,43
Net / gross depth	mm	484 / 540
	inch	19,06 / 21,26
Net / gross height	mm	985 / 1.130
	inch	38,78 / 44,49
Net / gross weight gross	Kg	124 / 134
	Lb	273,37 / 295,42
Net / gross volume gross	m³	0,79 / 1,03
	ft³	27,90 / 36,37

OTHERS

No. Fume outlet	Nº	-
Ø Fume outlet	mm	-
	inch	-
Air flow	m³/h	-
	cfm	-
Noise Level	dB	55

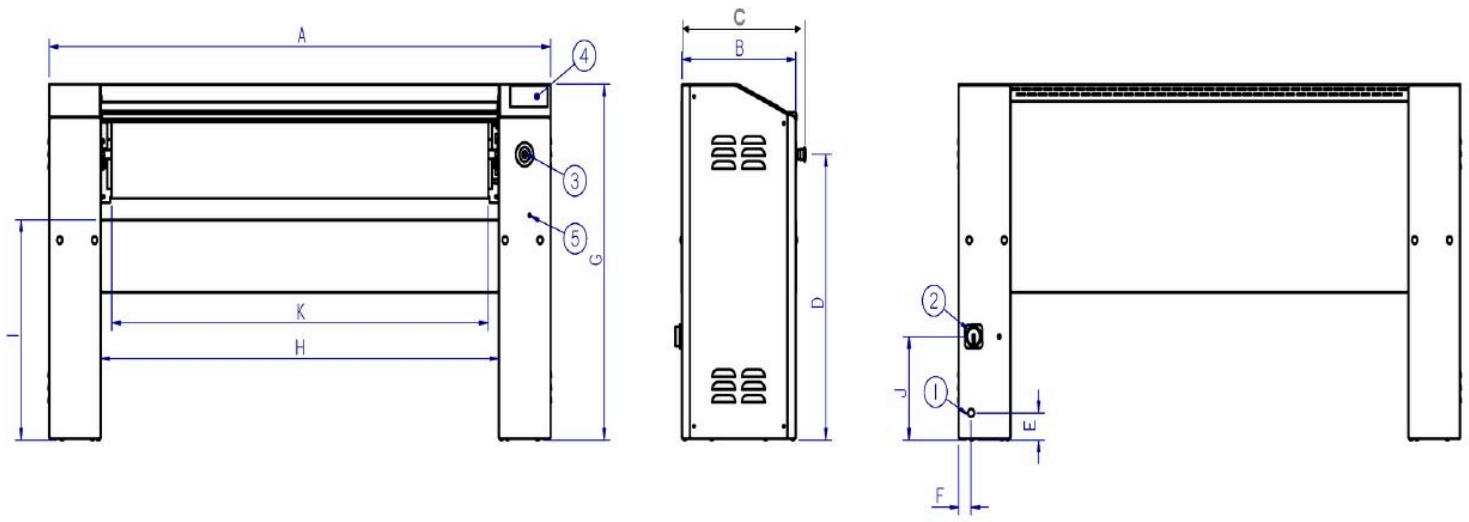

- 01. Electrical connection
- 02. Main switch
- 03. Emergency stop
- 04. Control panel
- 05. access to inverter maintenance

	A	B	C	D	E	F	G	H	I	J	K
PN-100/25	1.462	423	484	791	75	45	985	1.079	610	287	998
PN-120/25	1.662	423	484	791	75	45	985	1.279	610	287	1.198
PN-140/25	1.862	423	484	791	75	45	985	1.479	610	287	1.398
PN-200/25	2.462	423	484	791	75	45	985	2.079	610	287	1.998