



# Primer

## SPE800-2-2600

## SPE Flatwork Ironers

### FEATURES

Flatwork ironer with woll sizes: 2.600 and 3.300mm long and diameter 600, 800 and 1.000mm.

Panels in painted steel.

One or two working lanes: one lane for bedsheets and two lanes for tablecloth and smaller pieces.

Length fold (1 or 2 folds) and crossfold (up to 3 folds).

Folding system by photocells and compressed air.

Two types of linen stacker, with possibility to program the number of items stacked. The stacker can be positioned on either side of the machine.

Frequency control.

Feeding and ironing belts are NOMEX.

Touch-screen control: programs can be created with speed control (between 3 and 18mts/min), temperature and folding parameters.

Automatic stop after cooling down (at 80°C).

Big output capacity, depending on the residual moisture of the linen, up to 290kg/hour directly from the high spin washer extractor.

Electric, gas or steam heating.

Efficient gas models with radiant burner (increase of 25% more production, available in diameter 800 models and standard in diameter 1.000 models).

Powerful exhaust system.



### OPTIONS

- Stacker - it can stack up to 10 - 15 tablecloth, 10 bedsheets
- Compact (roll-off) stacker - it can stack up to 5 tablecloth
- Vacuum table to help the linen feeding
- Automatic 1 lane clamp feeder without vacuum feeding belts
- By pass for rear exit or to adapt Smarty
- Rear exit with table + bypass
- Small pieces back collector: 2 lanes + bypass included
- Small pieces back collector: 4 lanes + bypass included
- Double air pressure in length folds for thicker linen
- Linen reject system (dirty or torn)
- Remote service
- Different voltage from 400V III +N 50 Hz
- Maintenance Kit for Ironers
- Maritime packaging SPE
- Maritime packing for side stacker
- Maritime packing for ROLL OFF
- Maritime packing for small pieces collector 2 lanes
- Maritime packing for small pieces collector 4 lanes

Compact Stacker  
(roll-off)

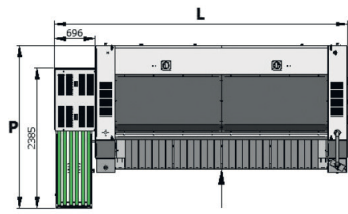

Stacker

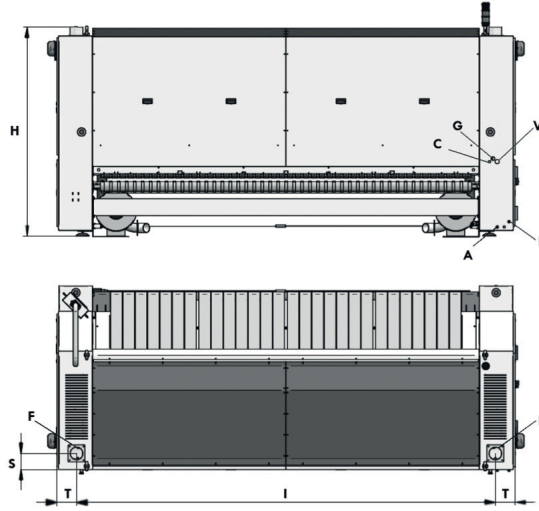
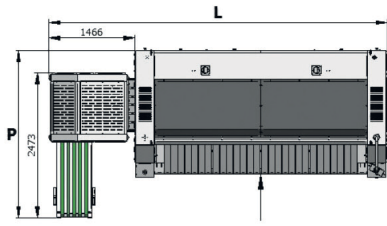

- A. Compressed air inlet
- C. Condensation discharge (steam models)
- E. Electrical connection
- F. Fumes extraction
- G. Gas inlet
- V. Steam inlet

Compact Stacker

Stacker

	L	P
SPE800-2600	4.425	2.385
SPE800-3300	5.125	2.385

	L	P
SPE800-2600	5.105	2.476
SPE800-3300	5.805	2.476

	H	I	T	S	A	C	E	F	G	V	W
SPE800-2600	1.867	1.196	1.208	478	Ø 12	1/2"	5G4	Ø 160	1"	1"	765
SPE800-3300	1.867	1.896	1.208	478	Ø 12	1/2"	5G4	Ø 160	1"	1"	765