



T2 CONTROL

User friendly and totally programmable 7" T2.
 USB Connection.
 Online platform free of charge for programming, telemetry, data analysis...thanks to the IoT.
 Videos on display (ads, instructions, etc.).
 37 languages.

OUTSTANDING FEATURES

Reversing drum action as standard.
 Stainless steel drum as standard.
 Frequency inverter as standard.

EFFICIENCY

SMART DRY: Intelligent humidity control with a new drum inlet temperature control.
 AIR RECOVERY SYSTEM: Efficient air recirculation system
 INSULATED PANEL: Complete air-flow circuit and double glass in the door.
 FULL FLOW: Optimized system of mixed airflow.
 Big fluff filter.

CONNECTIVITY

IoT - **PRIMERLINK** standard.
 Management of laundries.

VERSATILITY

Make to order: Customisation.
 Wet Cleaning.

ERGONOMICS

Drawer as fluff filter, stainless steel mesh.
 Biggest door diameters.
 Opening sense of door adjustable on site.

EASY MAINTENANCE

Hinged control panel: easy and ergonomic access.
 Technical menu: statistics for technicians.

OTHERS

Grey skinplate outer casing, stainless steel look.
 Integrated Fire Extinguishing System.
 EFFICIENT DRUM: the new drum with stamped holes.
 COOL DOWN: anti-wrinkle at the end of the cycle.
 Heating options: electric, gas and steam.
 CE approved.

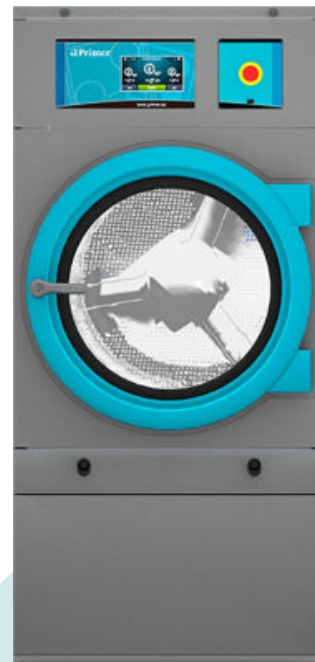

OPTIONS

- License IoT - PrimerLink
- Opposite door opening DE-11 to 35
- Tropicalized model
- Perfume dosage
- Back panel with air filter DE-11 to 35
- Fluff filter with grid 0,6mm (standard is 0,3mm)
- Fluff filter with grid 1,2mm (standard is 0,3mm)
- Stainless steel front and side panels DE-22
- Front panel in stainless steel DE-22
- Steam battery in stainless steel DE-22
- Low pressure steam battery DE-22
- NG gas option (Natural)
- 400 V III N 60 Hz DE-11 to 35
- 230 V III 50 Hz DE-22/28/35 E
- 230 V III 60 Hz DE-22/28/35 E
- 230 V III 60 Hz DE-11 to 35 G/S
- 440/480V III 60 Hz DE-22/28/35
- Maritime wooden packing DE-22

CAPACITY & DRUM	UNIT.	DE-22 T2
Capacity 1/18	Kg	24,3
	lb	53,9
Capacity 1/20	Kg	22
	lb	48,5
Ø Drum	mm	835
	inch	32,87
Drum length	mm	800
	inch	31,5
Drum volume	l	440
	cu ft	15,54
Ø Door hole	mm	574
	inch	22,60
Door center height	mm	1.030
	inch	40,55
Height from floor to bottom of door	mm	672
	inch	26,46
ELECTRIC HEATING		
Evaporation capacity	L/h	20
	US gallon/h	5,3
Hourly output	Kg/h	40
	lb/h	88,2
Installed heating power	kW	24
Installed electrical power	kW	25,17
Drum motor power	kW	0,37
GAS HEATING		
Evaporation capacity (gas model)	L/h	22,30
	US gallon/h	5,891
Hourly output (gas model)	Kg/h	44,60
	lb/h	98,3
Installed gas heating power	kcal/h	26655
	Btu/h	105775,6
Installed gas heating power	kW	31
Installed electrical power	kW	1,17
Instant propane gas consumption (G31)	Kg/h	2,66
	lb/h	5,86
Instant natural gas consumption (G20)	m ³ /h	3,28
	cfm	1,93
Ø Gas inlet	BSPP ISO 228-1	1/2"
STEAM HEATING		
Installed steam heating power	kW	49,20
	Btu/h	167877
Installed electrical power	kW	1,17
Steam consumption (8 barG) - Standard	kg/h	87
Steam consumption (116 psiG)	lb/h	104,8
Steam pressure	barG	6 - 9
	psiG	87 - 130,5
Standard steam inlet - outlet	BSPT- ISO7.1	1"
Standard steam inlet - outlet	NPT ANSI B1.20.1 Tapered	1"
Steam pressure (low pressure)	barG	3 - 6
	psiG	43,5 - 94
Low pressure steam inlet - outlet	BSPT- ISO7.1	1"
THERMAL OIL HEATING		
Installed heating power	kW	-
Installed electrical power	kW	-
Fluid consumption (T max 175°C)	m ³ /h	-
Thermal oil connection	BSP	-



VENTILATION			
Fan motor power	kW	0,75	
Nominal air flow rate	m ³ /h	1.500	
	cfm	882,87	
Ø Fume exhaust	mm	200	
Ø Fume exhaust	inch	7,87	
HEAT EMISSION			
Maximum total heat emission	kW	1,92	
	Btu/h	6555,1	
Max. front heat emission	kW	1,2	
	Btu/h	4097	
CONNECTIONS		E	G / S
Tension 230V - I + N + T	Nº x mm ² / A	-	3 x 1,5 / 16A
Tension 230V - III + T	Nº x mm ² / A	4 x 25 / 80A	3 x 1,5 / 16A
Tension 400V - III + N + T	Nº x mm ² / A	5 x 10 / 40A	3 x 1,5 / 16A
NET DIMENSIONS / D. WITH PACKING			
Net / gross width	mm	890 / 970	
	inch	35,04 / 38,19	
Net / gross depth	mm	1.255 / 1.345	
	inch	49,41 / 52,95	
Net height / gross height without heating	mm	1.812 / 1.940	
	inch	71,34 / 76,38	
Net / gross weight	Kg	210 / 230	
	lb	462,97 / 507,06	
OTHERS			
Sound level	dB	65	

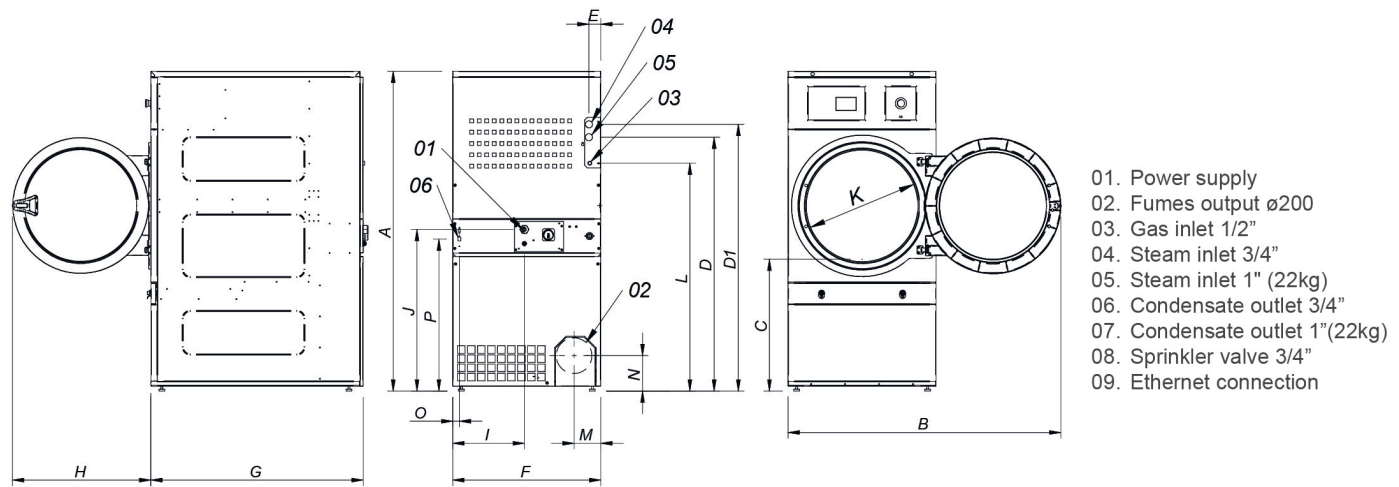

* Measurement with legs mounted (30mm)

	A	B	C	D	D1	E	E1	F	G	H	I	J	K	L	M	N	O	P	Q	R
DE-18	1694*	1447	689	1354	1422	68	68	785	1125	735	380	870	575	1226	133	180	830	65	35	805
DE-22	1812*	1552	743	1430	1532	112	55	890	1255	735	107	920	575	1344	238	180	885	65	37	860

