



Primer

SP800-3300

SP Flatwork Ironers

FEATURES

Flatwork ironer with roll sizes: 2.600 and 3.300mm wide and 600, 800 and 1.000mm diameter.

Panels in painted steel.

One or two working lanes: one lane for bedsheets and two lanes for tablecloths and small pieces.

Length fold with 1 or 2 folds in two independent lanes.

Folding system by photocells and compressed air.

Frequency control.

Feeding and ironing belts are NOMEX.

Touch-screen control: programs can be created with speed control (between 3 and 18 mts/min), temperature and folding parameters.

Automatic stop after cooling down (at 80°C).

Big output capacity, depending on the residual moisture of the linen, up to 290kg/hour straight from the high spin washer extractor.

Electric, gas or steam heating.

Powerful exhaust system.

Gas models with radiant burner (increase of 25% more production, available in diameter 800 models and standard in diameter 1.000mm models).



OPTIONS

- Vacuum table to help the linen feeding
- Automatic 1 lane clamp feeder without vacuum feeding belts
- Rear exit with table + bypass
- Crossfolder 330 + stacker for SP
- Motorized rear exit - height 860 mm. includes rear exit
- Small pieces back collector: 2 lanes for SP
- Small pieces back collector: 4 lanes for SP
- BY-PASS
- Double air pressure in length folds for thicker linen
- Linen reject system (dirty or torn)
- Different voltage from 400V III +N 50 Hz
- Maritime packing for SP

GENERAL DATA	UNIT.	SP800-3300
Theoretical production* elec/steam/atm. Gas heating	Kg/h	220
Theoretical production* radiant gas burner	Kg/h	253
Ø Roll	mm	800
Working width	mm	3.300
Height floor-feeding	mm	1.050
Working speed	mt/min	3-13
Control type	-	Digital
Nº of programs	Nº	20
FOLDING		
1 lane - lengthfold	Nº	1-2
2 lanes - lengthfold	Nº	1-2
POWER		
Electric heating	kW	72
Max. electric power electric heating	kW	74,2
Gas heating (natural / LPG)	kW	124,70 / 124,10
Max. electric power gas heating	kW	2,2
Steam heating	kW	110
Max. electric power steam heating	kW	2,2
CONNECTIONS		
Ø Gas inlet	BSP	1"
Ø Steam inlet (12 bar max.)	BSP	1"
Ø Condensed (steam models)	BSP	1/2"
Ø Air inlet	BSP	12
DIMENSIONS / PACKAGING DIMENSIONS		
Net width / gross width	mm	4.480 / 4.600
Net depth / gross depth	mm	1.770 / 2.220
Net height / gross height	mm	2.200 / 2.140
Net weight / gross weight	Kg	2.835 / 3.335
Volume	m3	17,45 / 21,85
OTHERS		
No. Fume outlet	Nº	2
Ø Fume outlet	mm	160
Extraction rate	m3/h	2 x 1.000
Compressed air consumption (6,5 bar)	mm	9.000
Sound Level	dB	70

* 50% residual moisture, 140gr/m² of cotton, 100% roll utilization

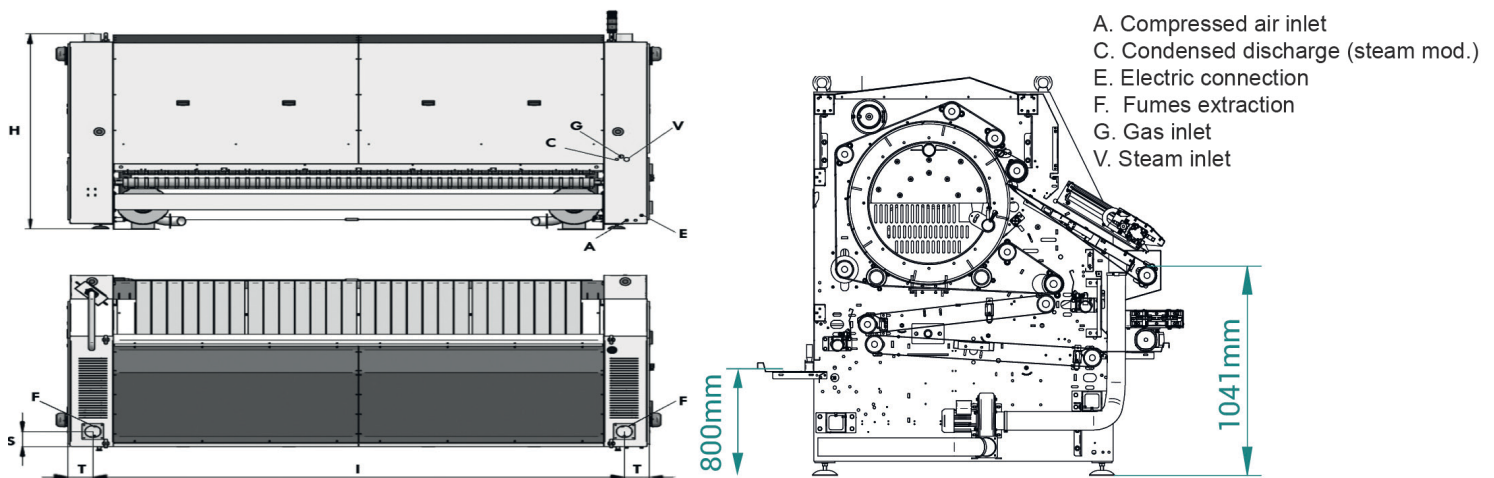

	H	I	T	S	A	C	E	F	G	V
S800-2600	1.966	3.242	186	152	Ø 12	1/2"	5 x 2,5	Ø 120	1"	1"
S800-3300	1.966	3.942	186	152	Ø 12	1/2"	5 x 2,5	Ø 120	1"	1"

