



Primer

DDS-18 XP

XP stack dryers STANDARD

OUTSTANDING FEATURES

Reversing drum action as standard.
Stainless steel drum as standard.
Frequency inverter as standard.

EFFICIENCY

DOUBLE FLOW - mixed axial-radial airflow.
Big fluff filter.

VERSATILITY

Make to order - Customisation
OPL > Self-service - Standard OPL model easily trasformable to coin laundry uses.

ERGONOMICS

Drawer as fluff filter, stainless steel mesh.
Biggest door diameters.

EASY MAINTENANCE

Hinged control panel: easy and ergonomic access.
Technical menu: statistics for technicians and maintenance with external console (with console option).

OTHERS

Grey skinplate outer casing, stainless steel look.
EFFICIENT DRUM- new drum with stamped holes.
COOL DOWN - anti-wrinkle at the end of the cycle.
Heating options: electric or gas except DDS-22 XP only gas.
CE approved

P CONTROL

P control: push buttons to control temperature and time.

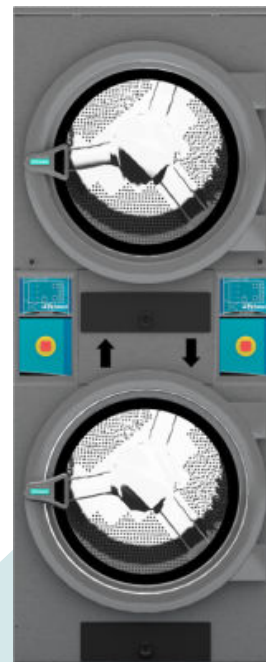

OPTIONS

- 400V 3~60Hz 11/14/18/22 XP
- Reduced power (12 kW) instead of 18 kW (Mod. 14, 18)
- Double doorglass (order 1 unit per column)
- Screen in P programmer (2 units)
- Fluff filter with grid 0,3 mm (standard in STACK is 0,6 mm)
- Stainless steel AISI 304 outer casing for DDS-18
- Stainless steel AISI 304 front panel for DDS-11/14/18
- NG gas option (Natural) for DDS
- Maritime wooden packing DDS-18
- 400V 3~ 50 Hz 11/14/18/22 XP
- 400V 3N 60 Hz 11/14/18/22 XP
- 230V 3~ 60 Hz 11/14/18/22 G XP
- 230V 3~ 60 Hz 11/14/18 E XP
- 440/480V 3~ 60 Hz 11/14/18/22 XP (marine)
- Several payment systems for self-service

CAPACITY & DRUM		UNIT.	DDS-18 XP	
Capacity 1/18		Kg	18,3 x 2	
		lb	40,3 x 2	
Capacity 1/20		Kg	16,5 x 2	
		lb	36,4 x 2	
Ø Drum		mm	750	
		inch	29,5	
Drum length		mm	746	
		inch	29,4	
Drum volume		l	330	
		cu ft	11,64	
Ø Door hole		mm	574	
		inch	22,6	
Door center height		mm	547 / 1522	
		inch	21,54 / 59,92	
Height from floor to bottom of door		mm	189 / 1164	
		inch	7,32 / 45,83	
ELECTRIC HEATING				
Evaporation capacity		L/h *	15,5 x 2	
		US gallon/h *	3,96 x 2	
Hourly output		Kg/h **	31 x 2	
		lb/h **	66,1 x 2	
Installed heating power		kW	18 x 2	
Installed electrical power		kW	37,34	
GAS HEATING				
Evaporation capacity (gas model)		L/h	16 x 2	
		US gallon/h	4,22 x 2	
Hourly output (gas model)		Kg/h	32 x 2	
		lb/h	70,9 x 2	
Installed gas heating power		kcal/h ***	17627 x 2	
		Btu/h ***	69996 x 2	
		kW ***	20,5 x 2	
Installed electrical power		kW	1,34	
Consumption of propane gas average (G31)		Kg/h	0,82 x 2	
		lb/h	1,82 x 2	
Instant natural gas consumption (G20)		m ³ /h	2,17 x 2	
		cfm	1,28 x 2	
Ø Gas inlet		BSPP ISO 228-1	3/4"	
POWER AND VENTILATION				
Drum motor power		kW	0,37 x 2	
Fan motor power		kW	0,25 x 2	
Nominal air flow rate		m ³ /h	500 x 2	
		cfm	294,28 x 2	
Ø Fume exhaust		mm	200	
		inch	7,87	
HEAT EMISSION				
Maximum total heat emission 10-8% (9-7%)		kW	3,3	
		Btu/h	11198	
Max. front heat emission 7-5% (4-2%)		kW	1,2	
		Btu/h	4199	
CONNECTIONS			E	G / S
Tension 230V - I + N + T		Nº x mm ² / A	-	3 x 2,5 / 16 (5*)
Tension 230V - III + T		Nº x mm ² / A	4 x 50 / 125	3 x 2,5 / 16 (5*)
Tension 400V - III + N + T		Nº x mm ² / A	5 x 16 / 63	3 x 2,5 / 16 (6*)
NET DIMENSIONS / D. WITH PACKING				
Net / gross width		mm	785 / 865	
		inch	30,9 / 34,1	



Net / gross depth	mm	1271 / 1354
	inch	50 / 53,3
Net / gross height	mm	1994 / 2126
	inch	78 / 83,7
Net / gross weight	Kg	314 / 329
	lb	692 / 725
OTHERS		
Max. sound level (at 1m in front)	dB	64

* Drying conditions: full load (1/20) of towels, drying temperature 90°C.

** Kg dry linen per hour. Drying conditions: full load (1/20) of towels, drying temperature 90°C.

*** Calculation of thermal power from PCI.

(5*) Connect 2 phases and earth.

(6*) Connect phase, neutral and earth.

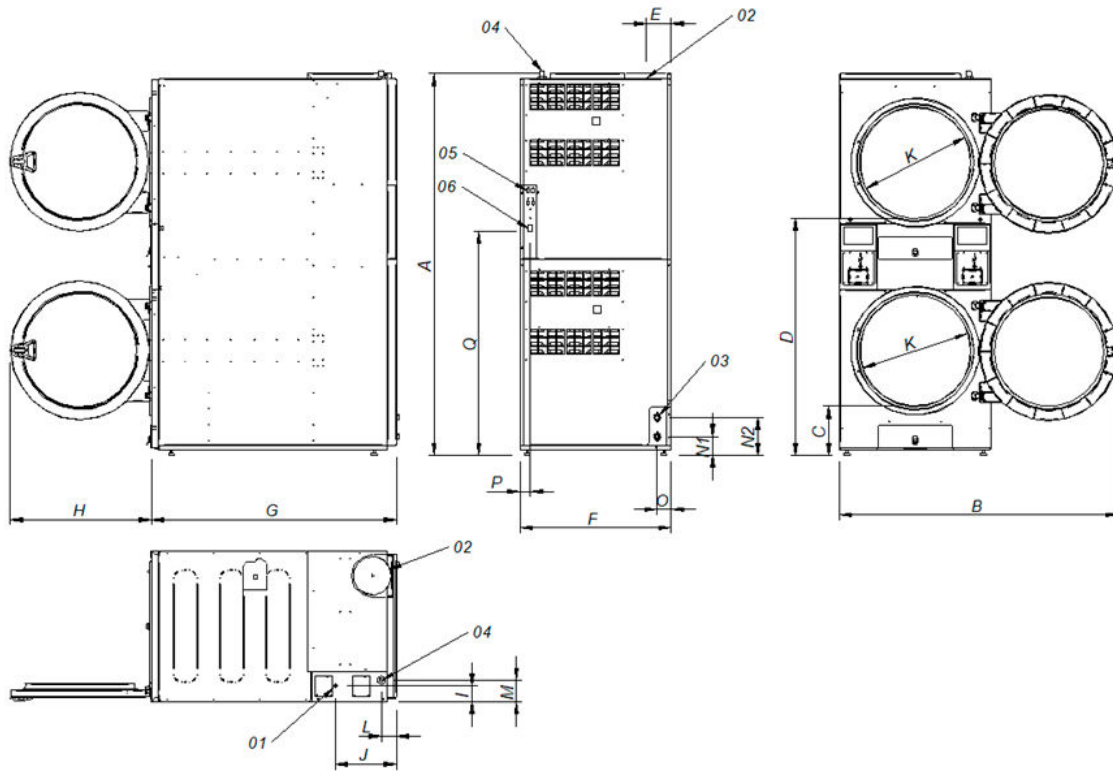

- 01. Power supply
- 02. Fumes output Ø200
- 03. 2 Sprinkler valves 3/4"
- 04. Gas inlet 3/4"
- 05. Ethernet connection (only T2 control)
- 06. ON/OFF control rocker switch

		A	B	C	D	E	F	G	H	I	J	K	L	M	N1	N2	O	P	Q
DDS-18 XP	mm	1980	1447	259	1234	131	785	1271	735	83	318	575	77	113	97	197	73	54	1163