



T2 CONTROL

User friendly and totally programmable 7" T2.
 USB Connection.
 Online platform free of charge for programming, telemetry, data analysis...thanks to the IoT.
 Videos on display (ads, instructions, etc.).
 37 languages.

OUTSTANDING FEATURES

Reversing drum action as standard.
 Stainless steel drum as standard.
 Frequency inverter as standard.

EFFICIENCY

SMART DRY: Intelligent humidity control with a new drum inlet temperature control.
 AIR RECOVERY SYSTEM: Efficient air recirculation system
 INSULATED PANEL: Complete air-flow circuit and double glass in the door.
 FULL FLOW: Optimized system of mixed airflow.
 Big fluff filter.

CONNECTIVITY

IoT - **PRIMERLINK** standard.
 Management of laundries.

VERSATILITY

Make to order: Customisation.
 Wet Cleaning.

ERGONOMICS

Drawer as fluff filter, stainless steel mesh.
 Biggest door diameters.
 Opening sense of door adjustable on site.

EASY MAINTENANCE

Hinged control panel: easy and ergonomic access.
 Technical menu: statistics for technicians.

OTHERS

Grey skinplate outer casing, stainless steel look.
 Integrated Fire Extinguishing System.
 EFFICIENT DRUM: the new drum with stamped holes.
 COOL DOWN: anti-wrinkle at the end of the cycle.
 Heating options: electric, gas and steam.
 CE approved.

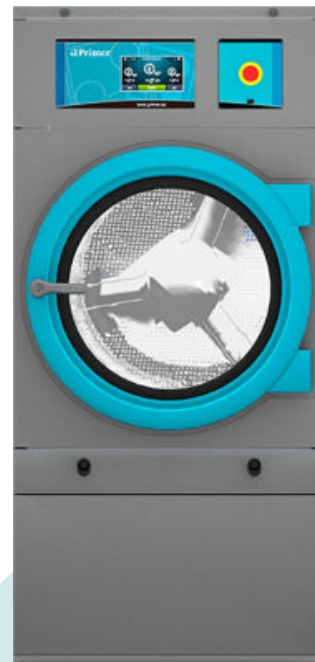

OPTIONS

- License IoT - PrimerLink
- Opposite door opening DE-11 to 35
- Tropicalized model
- Perfume dosage
- Back panel with air filter DE-11 to 35
- Fluff filter with grid 0,6mm (standard is 0,3mm)
- Fluff filter with grid 1,2mm (standard is 0,3mm)
- Stainless steel front and side panels DE-14/18
- Front panel in stainless steel DE-11/ 14/ 18
- Steam battery in stainless steel DE-11/ 14/ 18
- Low pressure steam battery DE-11/ 14/ 18
- NG gas option (Natural)
- 400 V III N 60 Hz DE-11 to 35
- 230 V III 50 Hz DE-11/14/18 E
- 230 V III 60 Hz DE-11/ 14/18 E
- 230 V III 60 Hz DE-11 to 35 G/S
- 440 / 480 V III 60 Hz DE-11/14/18 EXCELLENCE
- Reduced power (12kw instead of 18kw) for electric heated DE-14/18
- Maritime wooden packing DE-14/18

CAPACITY & DRUM		UNIT.	DE-18 T2
Capacity 1/18		Kg	18,3
		lb	40,4
Capacity 1/20		Kg	16,5
		lb	36,3
Ø Drum		mm	750
		inch	29,53
Drum length		mm	746
		inch	29,37
Drum volume		l	330
		cu ft	11,64
Ø Door hole		mm	574
		inch	22,60
Door center height		mm	976
		inch	38,43
Height from floor to bottom of door		mm	618
		inch	24,33
ELECTRIC HEATING			
Evaporation capacity		L/h	14,90
		US gallon/h	3,94
Hourly output		Kg/h	30
		lb/h	66,1
Installed heating power		kW	18
Installed electrical power		kW	18,97
Drum motor power		kW	0,37
GAS HEATING			
Evaporation capacity (gas model)		L/h	16,30
		US gallon/h	4,306
Hourly output (gas model)		Kg/h	33,60
		lb/h	74,1
Installed gas heating power		kcal/h	17638
		Btu/h	70000
Installed gas heating power		kW	20,51
Installed electrical power		kW	0,97
Instant propane gas consumption (G31)		Kg/h	1,76
		lb/h	3,88
Instant natural gas consumption (G20)		m ³ /h	2,17
		cfm	1,28
Ø Gas inlet		BSPP ISO 228-1	1/2"
STEAM HEATING			
Installed steam heating power		kW	30
		Btu/h	102364
Installed electrical power		kW	0,97
Steam consumption (8 barG) - Standard		kg/h	53
Steam consumption (116 psiG)		lb/h	63,8
Steam pressure		barG	6 - 9
		psiG	87 - 130,5
Standard steam inlet - outlet		BSPT- ISO7.1	3/4"
Standard steam inlet - outlet		NPT ANSI B1.20.1 Tapered	3/4"
Steam consumption (5 barG) - Low Pressure		kg/h	57
Steam consumption (72,5 psiG) - Low Pressure		lb/h	68,7
Steam pressure (low pressure)		barG	3 - 6
		psiG	43,5 - 92
Low pressure steam inlet - outlet		BSPT- ISO7.1	1"
THERMAL OIL HEATING			
Installed heating power		kW	-
Installed electrical power		kW	-
Fluid consumption (T max 175°C)		m ³ /h	-



Thermal oil connection	BSP	-	
VENTILATION			
Fan motor power	kW	0,55	
Nominal air flow rate	m ³ /h	1.200	
	cfm	706,29	
Ø Fume exhaust	mm	200	
Ø Fume exhaust	inch	7,87	
HEAT EMISSION			
Maximum total heat emission	kW	1,44	
	Btu/h	4916,4	
Max. front heat emission	kW	0,9	
	Btu/h	3072,7	
CONNECTIONS			
Tension 230V - I + N + T	Nº x mm ² / A	E	G / S
Tension 230V - III + T	Nº x mm ² / A	4 x 16 / 63A	3 x 1,5 / 16A
Tension 400V - III + N + T	Nº x mm ² / A	5 x 10 / 32A	3 x 1,5 / 16A
NET DIMENSIONS / D. WITH PACKING			
Net / gross width	mm	785 / 865	
	inch	30,91 / 34,06	
Net / gross depth	mm	1.125 / 1.210	
	inch	44,29 / 47,64	
Net height / gross height without heating	mm	1.694 / 1.840	
	inch	66,69 / 72,44	
Net / gross weight	Kg	187 / 200	
	lb	412,26 / 440,92	
OTHERS			
Sound level	dB	64	

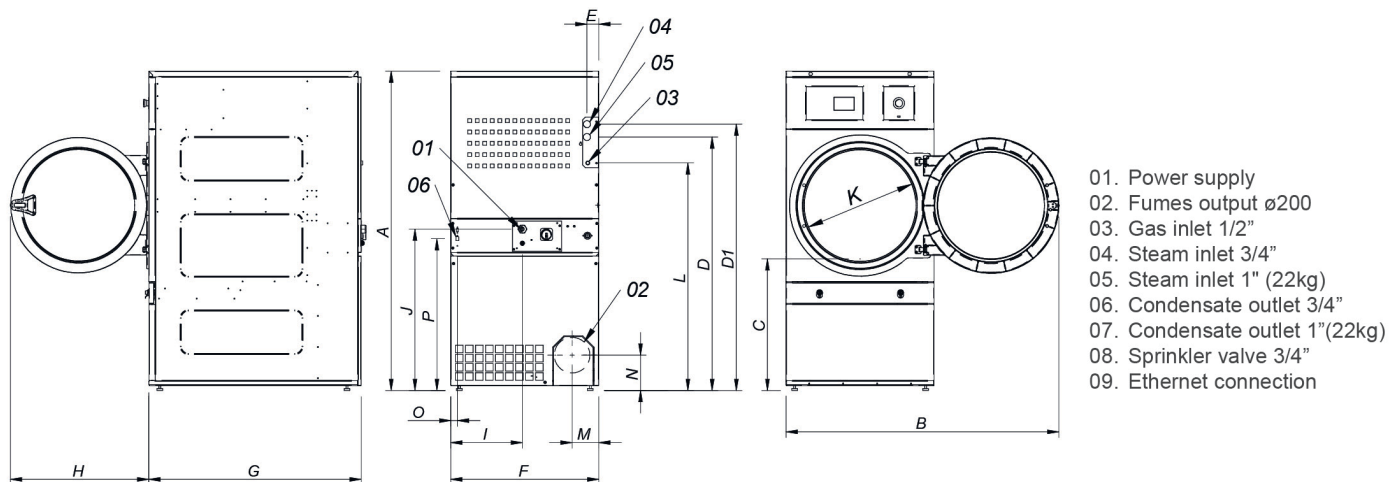

* Measurement with legs mounted (30mm)

	A	B	C	D	D1	E	E1	F	G	H	I	J	K	L	M	N	O	P	Q	R
DE-18	1694*	1447	689	1354	1422	68	68	785	1125	735	380	870	575	1226	133	180	830	65	35	805
DE-22	1812*	1552	743	1430	1532	112	55	890	1255	735	107	920	575	1344	238	180	885	65	37	860

