



Primer

LS-14 T2

High spin washers

T2 CONTROL

User friendly and totally programmable 7" USB Connection. Online platform free of charge for programming, telemetry, data analysis...thanks to the IoT Videos on display (ads, instructions, etc.)
37 languages
8 dosing signals as standard

G FACTOR

High G-Factor: G-FACTOR 500 (11 - 18 kg), for 450 (22 - 80 kg) and 350 (100 - 120kg).
It reduces the residual moisture.

CONNECTIVITY

PRIMERLINK - Standard and free IoT connectivity. Remote technical service.
Management for laundries: OPL and COIN.
Remote payment: **App PRIMER LAUNDRY** (mod. LS-11 up to LS-45C).

EFFICIENCY

Optimal KG.
Intelligent consumption: automatic adjustment of water and soap consumptions (standard).
Water Recovery tanks ready: **SAVETANK & SAVETANK XL**.
Low water consumption.

VERSATILITY

Make to order: customisation.
OPL < > COIN (mod. LS-11 up to LS-45C).
Electric < > Hot water.
Drain valve < > Pump (LS-11-14).
Wet Cleaning.

ERGONOMICS

Easy opening/closing system for door lock.
Biggest door diameters:
• Ø 373 (11, 14 kg)
• Ø 460 (18, 22, 28 kg)
• Ø 560 (35, 45, 60, 80 kg)
• Ø 700 (100, 120 kg)

EASY MAINTENANCE

Hinged control panel: easy and ergonomic access.
Technical menu: statistics for technicians.

OTHERS

Grey skinplate outer casing.
Drum and tub in stainless steel AISI 304.
Detergent dispenser with 4 compartments.
Electronic control of imbalance with frequency control.
LOADING AID feature: water and rotation control.
CB and WRAS approved product. Option ETL.
REG4 standard certified by KIWA.

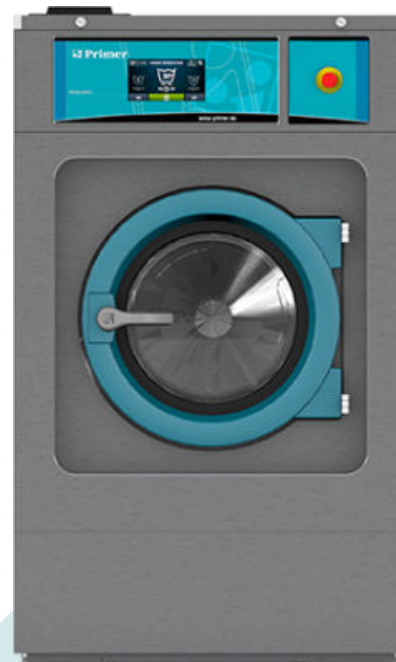

OPTIONS

- License IoT - PrimerLink
- DQ-2 Dosing pump kit. 2 pumps with guide support.
- Extra detergent dosage DB-1
- Double drain kit LS-14/18/22
- Drain pump kit LS-11/14
- Ready for SAVETANK conn. 3/4" for washers LS/RS-11 to 28
- Normally closed valve LS-14
- Recirculation of bath water LS-14. Not with SAVETANK
- Leveling Feet LS-11/14/18/22/28
- Weighing sensor system on feet LS-11 to LS-45C. Incl. kit 6 extra dosing signals
- 6 extra dosing signals card LS-11 to 45C
- Silicone door gasket LS-11/14
- Reversible door: reverse door opening
- Plinth MOPS with drawer LS-14 inox
- Steam kit LS-11/14/18/22
- Plinth MOPS with drawer LS-14 skinplate
- Stainless steel plinth LS-14 to level all machines from top
- skinplate plinth LS-14 to level all machines from top
- Door base alignment plinth at 850mm in stainless steel LS-14
- Door base alignment plinth at 850mm on skinplate LS-14
- Stainless steel outer casing LS-14
- Stainless steel front panel LS-14
- 440 V III No N 50/60 Hz LS-14 (maritime)
- Several payment systems for self-service

| DRUM | UNIT. | LS-14 T2 | |
|---|--------------|---------------|---------------|
| Capacity 1/9 | Kg | 14 | |
| Capacity 1/10 | Kg | 13 | |
| Volume | l | 130 | |
| Diameter | mm | 620 | |
| Depth | mm | 430 | |
| GENERAL DETAILS | | | |
| Washing speed / Spining speed | r.p.m. | 50 / 1.204 | |
| G Factor | - | 500 | |
| Maximum force transmitted | KN | 2,49 ±1,05 | |
| Frequency-dynamic force | Hz | 16,7 | |
| Noise level | dB | < 70 | |
| Coin laundry version | - | YES | |
| Double drain | - | OPT. | |
| Weighing system | - | OPT. | |
| Tilting door | - | NO | |
| DOOR | | | |
| Height center door / Height door | mm | 700 / 440 | |
| Diameter | mm | 373 | |
| POWER | | | |
| Motor | kW | 1,1 | |
| Electric heating power | kW | 9 | |
| Total electric power (electric model) | kW | 9,4 | |
| Total electric power (hw, steam model) | kW | 1,1 | |
| CONNECTIONS | | E | HW/S |
| Tension 110V - I + N + T | Nº x mm² / A | - | - |
| Tension 230V - I + N + T | Nº x mm² / A | 2x10+T - 50A | 2x1,5+T - 16A |
| Tension 230V - III + T | Nº x mm² / A | 3x4+T - 32A | - |
| Tension 400V - III + N + T | Nº x mm² / A | 4x1,5+T - 16A | - |
| Steam inlet (Steam model) | inch | 1/2" | |
| Maximum steam consumption (Steam model) | Kg/h | 8,5 | |
| Water inlet | inch | 3/4" | |
| Water main pressuer | Kg/cm² | 2-4 | |
| Maximum water consumption* | l / h | 88,8* | |
| Drain | mm/inch | 3" | |
| Drainage capacity | Lit/min | 200 | |
| DIMENSIONS / PACKING DIMENSIONS | | | |
| Net Width/Gross width | mm | 788 / 850 | |
| Net Depth/Gross depth | mm | 869 / 1.015 | |
| Net Height / Gross height | mm | 1.307 / 1.600 | |
| Net weight / Gross weight | kg | 236 / 274,5 | |
| Volume | m³ | 1,38 | |

* Program number 20: LS-11 to LS-80C at 75% load / LS-100C and 120C at 100% load.



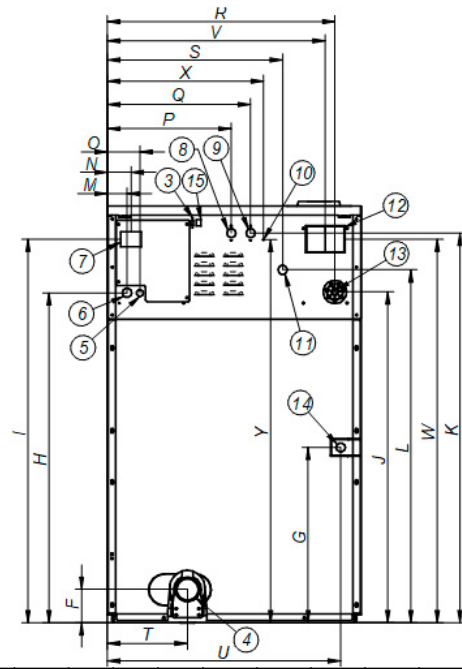
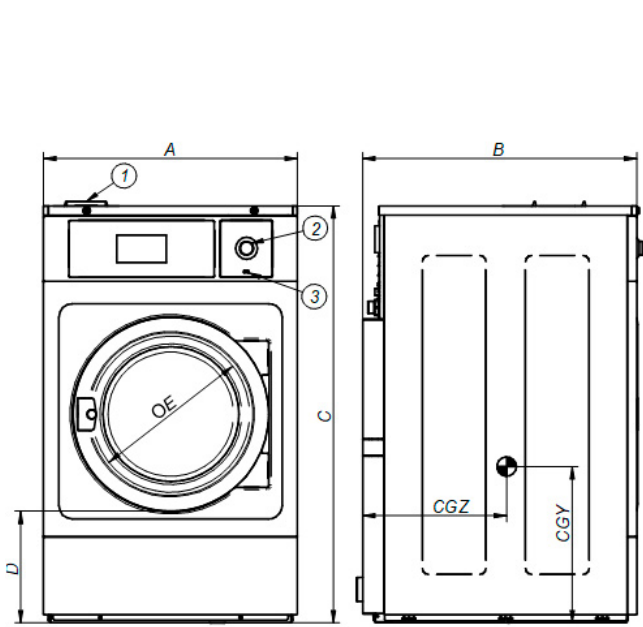

1. Soap dispenser
2. Emergency stop
3. USB port
4. Drain
5. Electric connection to liquid soap pumps
6. Electrical connection
7. Main switch
8. Auxiliar water inlet
9. Hot water inlet
10. Equipotential connection
11. Cold water inlet
12. Blur output / Water overload
13. Liquid soap connection
14. Steam connection
15. Ethernet port
16. Clean side light

| | | A | B | C | D | E | F | G | H | I | J | K | L | M | N | O | P | Q | R | S | T | U | V | W | X | Y | CGY | CGZ |
|-------|------|-------|-------|-------|-------|-------|------|-------|-------|-------|-------|-------|-------|------|------|------|-------|-------|-------|-------|------|-------|-------|-------|-------|-------|-------|-------|
| LS-14 | mm | 788 | 869 | 1.307 | 440 | 373 | 125 | 385 | 1.034 | 1.202 | 1.037 | 1.221 | 1.106 | 61 | 74 | 101 | 385 | 445 | 706 | 544 | 243 | 718 | 676 | 1.202 | 485 | 1.201 | 450 | 651 |
| | inch | 31,02 | 34,21 | 51,46 | 17,32 | 14,69 | 4,92 | 15,16 | 40,71 | 47,32 | 40,83 | 48,07 | 43,54 | 2,40 | 2,91 | 3,98 | 15,16 | 17,52 | 27,80 | 21,42 | 9,57 | 28,27 | 26,61 | 47,28 | 19,09 | 47,28 | 17,72 | 25,63 |