



Primer

CAB-V

Finishing cabinets

FEATURES

Cabinet supplied as standard with one trouser finishing device and one form finisher for jackets, coats, dresses, etc. Supplied with all the necessary accessories for the finishing of trousers, jackets and coats (dummy, trousers waist band stretcher, curved clamp for jackets, straight trouser clamps, vertical clamps, multiple connection, wooden and silicon sleeve stretchers).

- Controlled by an easy to use microprocessor, capable of running up to nine fully automatic programs, amendable by the user.
- Automatic starting cycle after door closing.

CAB-V MODEL

- **Without steam boiler**, to be connected to a central steam supply.
- It needs a steam inlet and outlet.
- Electrical connection: 230/400V III 50-60Hz.

CAB-A MODEL

- **Complete with built-in steam boiler, 16 litres**, with automatic water feeding and automatic pressure control (4,5 bar).
- Electrical connection: 230/400V III 50-60Hz.



OPTIONS

- Leg stretcher

GENERAL DETAILS	UNIT.	CAB-V
Boiler	-	YES
Boiler capacity	L	16
POWER		
Pump motor	HP	0,75
Compressor motor	kW	15
Boiler heater	kW	12
Fan motor	kW	1-1,5
CONNECTIONS		
Ø Water inlet	BSP	3/8"
Ø Boiler exhaust (mod. with boiler)	BSP	1/2"
Ø Steam inlet	BSP	-
Boiler drain	BSP	1/2"
Steam pressure	BAR	4-5
Steam consumption	Kg/h	16-20
Ø Air inlet	BSP	1/4"
Ø Air outlet	mm	140
Air pressure	BSP	4-5
Air Consumption	NI/min	6
NET DIMENSIONS / PACKING DIMENSIONS		
Net width / Gross width	mm	1.080 / 1.080
Net depth / Gross depth	mm	1.375 / 1.190
Net height / Gross height	mm	1.850 / 2.020
Net weight / Gross weight	Kg	241 / 309
Volume	m ³	2,75 / 2,60
OTHERS		
Tension	V/Hz	230/400V III 50-60
Sound level	dB	65

CAB-A

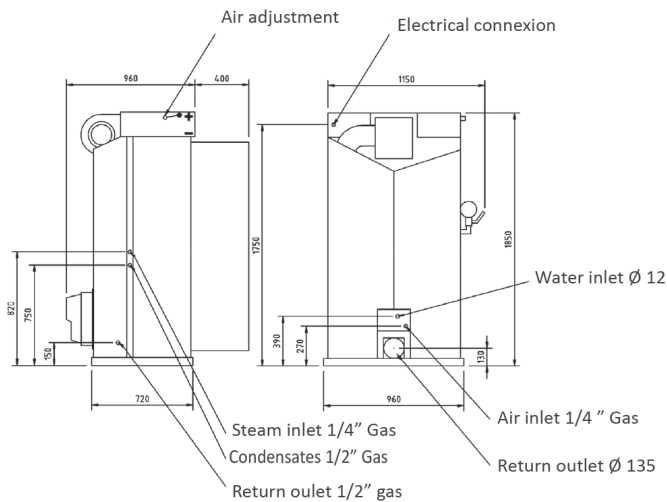

CAB-V

