



Primer

SAVETANK XL

SAVETANK XL: Water recovery tanks

SAVETANK XL tanks are the ideal solution for optimising water consumption in your laundry.

Ideal for large businesses and large capacity machines.

OUTSTANDING FEATURES

High-capacity tanks designed to store up to 1000 litres, allowing for significant water savings.

Compatible:

Different SAVETANK XL units can be combined with various Primer machines featuring T2:

- 1, 2, or 3 SAVETANK XL tanks.
- 1 or more machines with the SAVETANK XL units.

Durable: Manufactured from high-density polyethylene with an external reinforcement of galvanised steel structure.

EFFICIENCY

Up to **40 and 70% savings***.

Detergent savings: By optimising the use of water in different phases of the wash, SAVETANK XL reduce the need for chemicals to treat the water.

*Depending on the types of programs, garments and processes.

EASY INSTALLATION & MAINTENANCE

Fixing: Incorporate holes for easy anchoring to the floor.

Accessory kit available: To easily connect the washers and barriers with the tanks (option).

2 water level sensors: on each SAVETANK, indicating the minimum and maximum level.

OTHERS

One or more washing machines can be connected so that the wash water can be reused.

Sold separately.

No external panels, only the frame.

Required: Water and electricity connections (connections not included with the tank).

Make connections between machines and tanks: hose kit and fittings available as an option to connect 1 washer/barrier to 3 tanks.

MACHINES THAT CAN BE CONNECTED WITH SAVETANK XL

up to 8 * 35/45 kg washers

up to 4 * 60/80 kg washers

up to 3 * 100/120 kg washers



OPTIONS

- Ready for SAVETANK XL conn. 1" for barriers for LCA-100
- Kit ready for SAVETANK 1" for barriers LCA-27
- Kit ready for SAVETANK 1" for barriers LCA-35
- Kit ready for SAVETANK 1" for barriers LCA-50
- Kit ready for SAVETANK 1" for barriers LCA-70
- Kit ready for SAVETANK XL 1" for washers LS/RS-100C
- Kit ready for SAVETANK XL 1" for washers LS/RS-35C/45C
- Kit ready for SAVETANK XL 1" for washers LS/RS-60C/80C
- SAVETANK XL Elevated Platform
- Hose kit and accessories for the installation of SAVETANK XL (1 per washer)

TANKS	UNIT.	SAVETANK XL
Tanks	l	1.000
Front-load washing machine capacity	Kg	35, 45, 60, 80, 100, 120
Front-load washing machine barrier	Kg	27, 35, 50, 70, 100
Outdoor furniture	-	skinplate
CONNECTIONS		
Water inlet	inch	1"
Water outlet	inch	1"
Fumes outlet	mm	70
Drain Ø	mm	1"
DIMENSIONS / PACKING DIMENSIONS		
Net width / Gross width	mm	702 / 785
Net depth / Gross depth	mm	1.375 / 1.450
Net height / Gross height	mm	2.206 / 2.262
Net weight / Gross weight	Kg	147 / 173
Volume	m ³	-

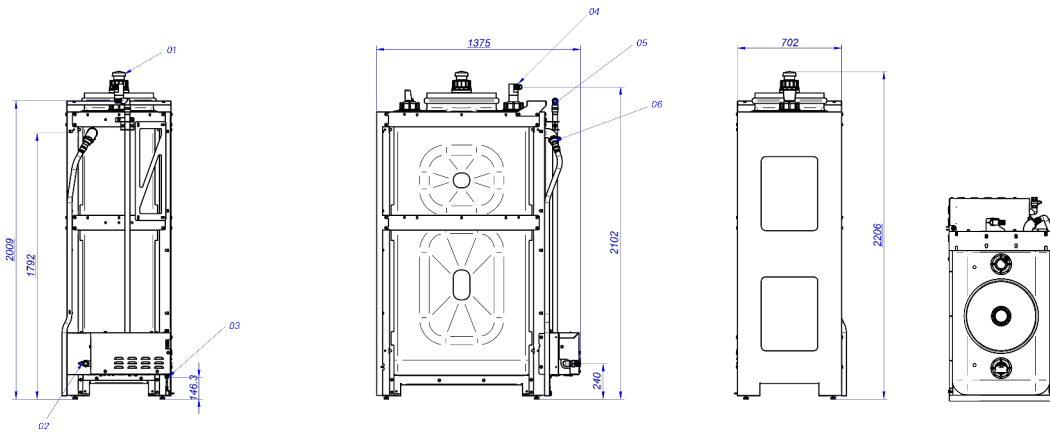

- 01. Breather
- 02. Tank manual download
- 03. Power supply
- 04. Water inlet from washers
- 05. Water outlet to washers
- 06. Overflow