



# Primer

## DP-10 T2 HPi HPi Professional tumble dryers with HEAT PUMP



### T2 CONTROL

- User-friendly and fully programmable T2 with 4.3" colour touch screen.
- Precise control, fully programmable and configurable.
- PRIMERLINK: standard and free IoT.
- Videos on display (ads, instructions, etc.).
- More than 35 languages available.



### EASY INSTALLATION & MAINTENANCE

- **No water connection required for cooling:**
  - Fewer maintenance points.
- **No need for external extraction:**
  - No exhaust required.
  - Less space required.
  - Less installation work and no special permits needed.
- Front access to the heat pump and filters.



### OUTSTANDING FEATURES

- Drum rotation reversal.
- Frequency inverter.
- Double dedicated lint filter.
- Stainless steel drum.



### VERSATILITY

Make to order - customisation  
Wet Cleaning.  
OPL > Multivending - Standard OPL model easily transformable to coin laundry uses.



### EFFICIENCY

- Highly efficient: direct savings.
- EFFICIENT DRY: moisture sensor.
- Drum rotation reversal.
- Frequency inverter.
- Axial airflow system.



### CONNECTIVITY

- **PRIMERLINK:** free IoT as standard.
- Laundry management: OPL and coin laundry, remotely.
- Remote assistance.
- Revenue control (self-service) and much more.



### ROBUSTNESS

- Outer cabinet in grey skinplate.
- Robust aluminium door.
- Powerful airflow.
- Robust construction of the frame and panels.
- Wide ambient temperature range.



### OTHERS

- **FULL SCREEN FILTER:** Fluff filter as drawer, not in the door.



### OPTIONS

- License IoT - PRIMERLINK
- Reverse door opening
- Outer casing stainless steel AISI 430 for HPi
- Tropicalized model: protected board (T2)
- 440/480V 3~ 50/60Hz HPi
- Several payment systems for self-service

CAPACITY	UNIT.	DP-10 T2 HPI
Capacity 1/18	Kg	11,1
	Lb	24,5
Capacity 1/20	Kg	10,0
	Lb	22
Evaporation capacity (elec. model)	L/h	4,3
	USGallon/h	1,14
Hourly output (elec. model)	Kg/h	8,6
	lb/h	18,96
Efficiency	kWh/L	0,43
DRUM		
Ø Drum	mm	590
	inch	23,2
Ø Door	mm	480
	inch	18,9
Door center height	mm	918
	inch	36,1
Load hole bottom height	mm	684
	inch	26,93
Drum length	mm	690
	inch	24,17
Drum volume	L	200
	cu ft	7,06
POWER		
Drum motor power	kW	0,37
Fan motor power	kW	0,17
Heating power	kW	2,2
Total electric power (elec. model)	kW	2,74
DIMENSIONS		
Net width	mm	680
	inch	26,8
Net depth	mm	784
	inch	30,9
Net height	mm	1.400
	inch	55,1
Net weight	Kg	169
	lb	373
PACKING DIMENSIONS		
Gross width	mm	710
	inch	28
Gross depth	mm	832
	inch	32,8
Gross height	mm	1.520
	inch	59,8
Gross weight	Kg	178
	lb	392
OTHERS		
Max airflow	m <sup>3</sup> /h	VARIABLE
Ø Fume exhaust	mm	NO
Sound level	dB	61
Drain for moisture extraction (hose)	Ø / Length (mm)	12/2000
	Ø / Length (inch)	0,47 / 78,74



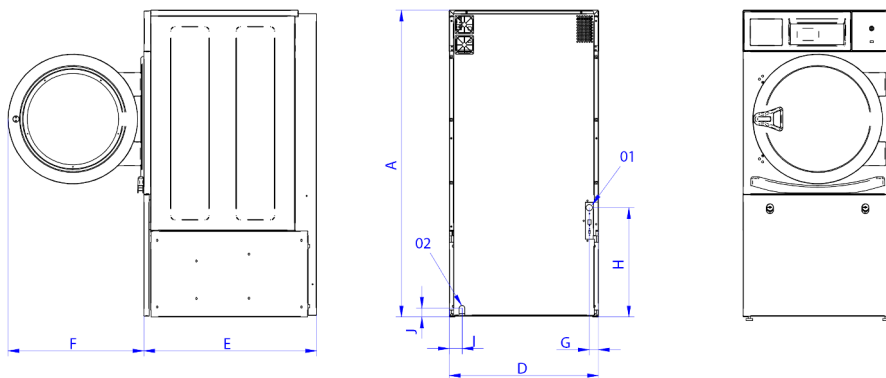

01. Electrical connection  
 02. Condensed water evacuation  
 3000mm hose (1) and 12mm diameter  
 (1) For greater distances, consult the installation manual.

		A	B	C	D	E	F	G	H	I	J	K
DP-8 T2 Hpi	mm	1.400	1.227	665	680	750	615	42	505	60	50	480
DP-10 T2 Hpi	mm	1.400	1.227	665	680	784	615	42	505	60	50	480

