



Primer

LS-11 T2

High spin washers

T2 CONTROL

User friendly and totally programmable 7" USB Connection. Online platform free of charge for programming, telemetry, data analysis...thanks to the IoT Videos on display (ads, instructions, etc.)
37 languages
8 dosing signals as standard

G FACTOR

High G-Factor: G-FACTOR 500 (11 - 18 kg), for 450 (22 - 80 kg) and 350 (100 - 120kg).
It reduces the residual moisture.

CONNECTIVITY

PRIMERLINK - Standard and free IoT connectivity. Remote technical service.
Management for laundries: OPL and COIN.
Remote payment: **App PRIMER LAUNDRY** (mod. LS-11 up to LS-45C).

EFFICIENCY

Optimal KG.
Intelligent consumption: automatic adjustment of water and soap consumptions (standard).
Water Recovery tanks ready: **SAVETANK & SAVETANK XL**.
Low water consumption.

VERSATILITY

Make to order: customisation.
OPL < > COIN (mod. LS-11 up to LS-45C).
Electric < > Hot water.
Drain valve < > Pump (LS-11-14).
Wet Cleaning.

ERGONOMICS

Easy opening/closing system for door lock.
Biggest door diameters:
• Ø 373 (11, 14 kg)
• Ø 460 (18, 22, 28 kg)
• Ø 560 (35, 45, 60, 80 kg)
• Ø 700 (100, 120 kg)

EASY MAINTENANCE

Hinged control panel: easy and ergonomic access.
Technical menu: statistics for technicians.

OTHERS

Grey skinplate outer casing.
Drum and tub in stainless steel AISI 304.
Detergent dispenser with 4 compartments.
Electronic control of imbalance with frequency control.
LOADING AID feature: water and rotation control.
CB and WRAS approved product. Option ETL.
REG4 standard certified by KIWA.



OPTIONS

- License IoT - PrimerLink
- DQ-2 Dosing pump kit. 2 pumps with guide support.
- Extra detergent dosage DB-1
- 3" EXTERNAL double drain kit (recom. LS-11)
- Drain pump kit LS-11/14
- Ready for SAVETANK conn. 3/4" for washers LS/RS-11 to 28
- Normally closed valve LS-11
- Recirculation of bath water LS-11. Not with SAVETANK
- Leveling Feet LS-11/14/18/22/28
- Weighing sensor system on feet LS-11 to LS-45C. Incl. kit 6 extra dosing signals
- 6 extra dosing signals card LS-11 to 45C
- Silicone door gasket LS-11/14
- Reversible door: reverse door opening
- Plinth MOPS with drawer LS-11 inox
- Steam kit LS-11/14/18/22
- Plinth MOPS with drawer LS-11 skinplate
- Stainless steel plinth LS-11 to level all machines from top
- skinplate plinth LS-11 to level all machines from top
- Door base alignment plinth at 850mm in stainless steel LS-11
- Door base alignment plinth at 850mm on skinplate LS-11
- Stainless steel outer casing LS-11
- Stainless steel front panel LS-11
- 440 V III No N 50/60 Hz LS-11 (maritime)
- Several payment systems for self-service

DRUM	UNIT.	LS-11 T2	
Capacity 1/9	Kg	11	
Capacity 1/10	Kg	10	
Volume	l	100	
Diameter	mm	532	
Depth	mm	425	
GENERAL DETAILS			
Washing speed / Spining speed	r.p.m.	50 / 1.300	
G Factor	-	500	
Maximum force transmitted	KN	2,08 ±0,75	
Frequency-dynamic force	Hz	16,7	
Noise level	dB	< 70	
Coin laundry version	-	YES	
Double drain	-	NO	
Weighing system	-	OPT.	
Tilting door	-	NO	
DOOR			
Height center door / Height door	mm	630/370	
Diameter	mm	373	
POWER			
Motor	kW	0,75	
Electric heating power	kW	6	
Total electric power (electric model)	kW	6,25	
Total electric power (hw, steam model)	kW	0,75	
CONNECTIONS		E	HW/S
Tension 110V - I + N + T	Nº x mm ² / A	-	-
Tension 230V - I + N + T	Nº x mm ² / A	2x6+T - 40A	2x1,5+T - 16A
Tension 230V - III + T	Nº x mm ² / A	3x2,5+T - 20A	-
Tension 400V - III + N + T	Nº x mm ² / A	4x1,5+T - 16A	-
Steam inlet (Steam model)	inch	1/2"	
Maximum steam consumption (Steam model)	Kg/h	7	
Water inlet	inch	3/4"	
Water main pressuer	Kg/cm ²	2-4	
Maximum water consumption*	l / h	71,4*	
Drain	mm/inch	3"	
Drainage capacity	Lit/min	200	
DIMENSIONS / PACKING DIMENSIONS			
Net Width/Gross width	mm	692 / 738	
Net Depth/Gross depth	mm	830 / 975	
Net Height / Gross height	mm	1.185 / 1.440	
Net weight / Gross weight	kg	198 / 230	
Volume	m ³	1,03	

* Program number 20: LS-11 to LS-80C at 75% load / LS-100C and 120C at 100% load.



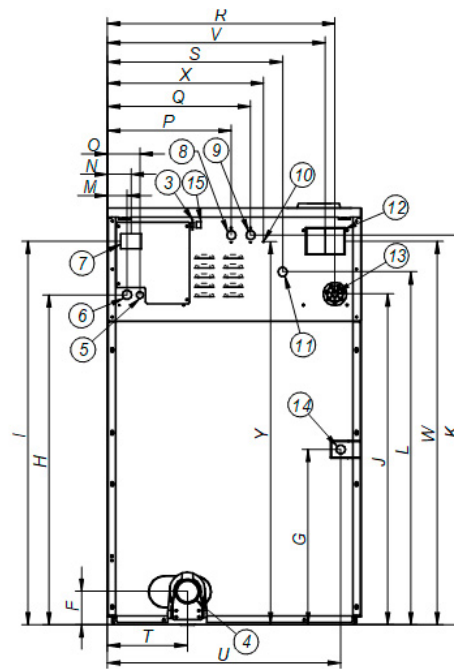
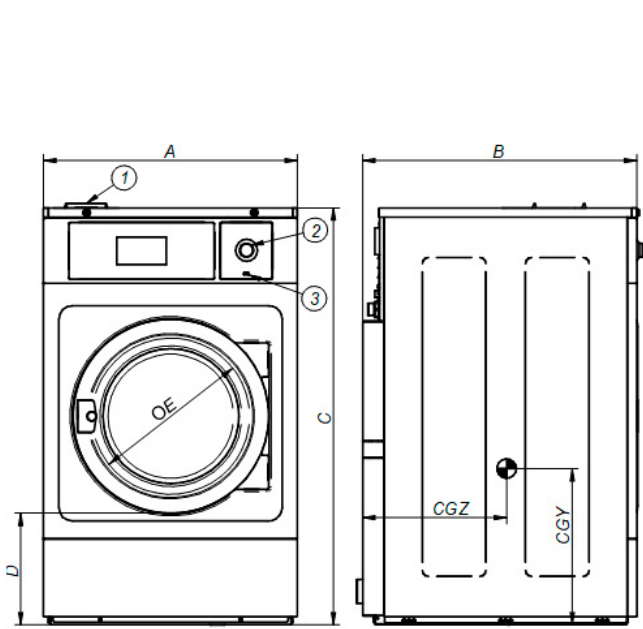

1. Soap dispenser
2. Emergency stop
3. USB port
4. Drain
5. Electric connection to liquid soap pumps
6. Electrical connection
7. Main switch
8. Auxiliar water inlet
9. Hot water inlet
10. Equipotential connection
11. Cold water inlet
12. Blur output / Water overload
13. Liquid soap connection
14. Steam connection
15. Ethernet port
16. Clean side light

		A	B	C	D	E	F	G	H	I	J	K	L	M	N	O	P	Q	R	S	T	U	V	W	X	Y	CGY	CGZ
LS-11	mm	692	830	1.185	370	373	125	354	913	1.085	916	1.100	985	61	74	101	292	352	610	448	226	626	580	1.080	442	1.145	424	577
	inch	27,24	32,68	46,65	14,57	14,69	4,92	13,94	35,94	42,72	36,06	43,31	38,78	2,40	2,91	3,98	11,50	13,86	24,02	17,64	8,90	24,65	22,83	42,52	17,40	45,08	16,69	22,72