



### T2 CONTROL

User friendly and totally programmable 7" T2.  
 USB Connection.  
 Online platform free of charge for programming, telemetry, data analysis...thanks to the IoT.  
 Videos on display (ads, instructions, etc.).  
 37 languages.

### OUTSTANDING FEATURES

Reversing drum action as standard.  
 Stainless steel drum as standard.  
 Frequency inverter as standard.

### EFFICIENCY

DUAL AIRFLOW: Optimized system of mixed airflow.  
 Big fluff filter.

### CONNECTIVITY

**IoT - PRIMERLINK standard.**  
 Managemnt of laundries: OPL and COIN.  
 Remote payment (self-service) on models from 11 to 35 kg.

### VERSATILITY

Make to order: customisation.  
 Wet Cleaning.  
 OPL > Multivending - Standard OPL model easily trasformable to coin laundry uses (11-35 kg).

### ERGONOMICS

Drawer as fluff filter, stainless steel mesh.  
 Biggest door diameters.  
 Opening sense of door adjustable on site.

### EASY MAINTENANCE

Hinged control panel: easy and ergonomic access.  
 Technical menu: statistics for technicians.  
 Easy access to parts for reparability.

### OTHERS

Grey skinplate outer casing, stainless steel look.  
 EFFICIENT DRUM: the new drum with stamped holes.  
 COOL DOWN: anti-wrinkle at the end of the cycle.  
 Heating options: electric, gas and steam.  
 CE approved.

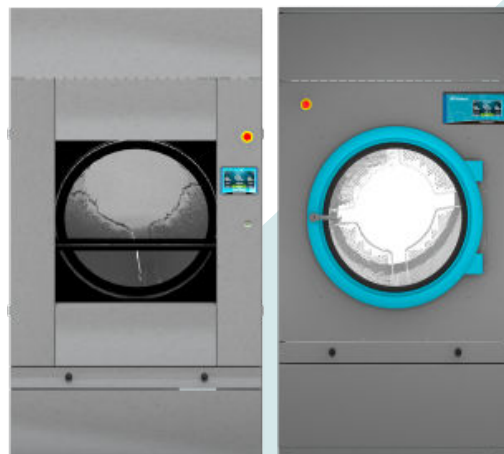

### OPTIONS

- License IoT - PrimerLink
- Automatic sliding door DO-45/60/80
- Manual sliding door DO-45/60/80 (no double glass)
- Frontal tilting kit for models DO-45/60/80
- Humidity control SMART DRY
- Double doorglass DO-28/35/45/60/80
- Fire extinguisher DO-60/80
- Opposite door opening DO-45/60/80
- Tropicalized model
- Perfume dosage
- Back panel with air filter DO-45/60/80
- Fluff filter with grid 0/6 mm (standard is 0/3 mm)
- Fluff filter with grid 1/2 mm (standard is 0/3 mm)
- Stainless steel front and side panels DO-60
- Front panel in stainless steel DO-45/60/80
- Low pressure steam battery DO-45/60/80
- Maritime wooden packing DO-60
- NG gas option (Natural)
- 400 V III N 60 Hz DO-45/60/80 E/S
- 400 V III N 60 Hz DO-45/60/80 G
- 220 V III 50 Hz DO-45/60/80 G
- 220 V III 60 Hz DO-45/60/80 E/S
- 220 V III 60 Hz DO-45/60/80 G
- 400 V III 50 Hz DO-60/80
- 230 V III 50 Hz 45/60/80 E
- 230 V III 60 Hz 45/60/80 E
- 440/480 V III 60 Hz DO-45/60/80

CAPACITY & DRUM	UNIT.	DO-60 T2
Capacity 1/18	Kg	66,7
	lb	146,9
Capacity 1/20	Kg	60
	lb	132,3
Ø Drum	mm	1.225
	inch	48,23
Drum length	mm	1.020
	inch	40,16
Drum volume	l	1.200
	cu ft	42,37
Ø Door hole	mm	802
	inch	31,57
Door center height	mm	1.275
	inch	50,20
Height from floor to bottom of door	mm	813
	inch	31,99
ELECTRIC HEATING		
Evaporation capacity	L/h	60,2
	US gallon/h	15,9
Hourly output	Kg/h	120
	lb/h	264,6
Installed heating power	kW	72
Installed electrical power	kW	74,25
Drum motor power	kW	1,10
GAS HEATING		
Evaporation capacity (gas model)	L/h	72
	US gallon/h	17,383
Hourly output (gas model)	Kg/h	128,6
	lb/h	283,5
Installed gas heating power	kcal/h	77386
	Btu/h	307092,7
Installed gas heating power	kW	90
Installed electrical power	kW	2,25
Instant propane gas consumption (G31)	Kg/h	7,71
	lb/h	17
Instant natural gas consumption (G20)	m <sup>3</sup> /h	9,53
	cfm	5,61
Ø Gas inlet	BSPP ISO 228-1	3/4"
STEAM HEATING		
Installed steam heating power	kW	128
	Btu/h	436754
Installed electrical power	kW	2,25
Steam consumption (8 barG) - Standard	kg/h	171
Steam consumption (116 psiG)	lb/h	206
Steam pressure	barG	7 - 12
	psiG	101,5 - 177
Standard steam inlet - outlet	BSPT- ISO7.1	1"
Standard steam inlet - outlet	NPT ANSI B1.20.1 Tapered	1"
Steam consumption (5 barG) - Low Pressure	kg/h	147
Steam consumption (72,5 psiG) - Low Pressure	lb/h	177,1
Steam pressure (low pressure)	barG	4 - 7
	psiG	58 - 101,5
Low pressure steam inlet - outlet	BSPT- ISO7.1	1" 1/2
THERMAL OIL HEATING		
Installed heating power	kW	128
Installed electrical power	kW	2,25
Fluid consumption (T max 175°C)	m <sup>3</sup> /h	10



Thermal oil connection	BSP	1" 1/2	
<b>VENTILATION</b>			
Fan motor power	kW	1,1	
Nominal air flow rate	m <sup>3</sup> /h	3.000	
	cfm	1765,73	
Ø Fume exhaust	mm	300	
Ø Fume exhaust	inch	11,81	
<b>HEAT EMISSION</b>			
Maximum total heat emission	kW	6,48	
	Btu/h	22123,6	
Max. front heat emission	kW	2,88	
	Btu/h	9832,7	
<b>CONNECTIONS</b>			
Tension 230V - I + N + T	Nº x mm <sup>2</sup> / A	-	-
Tension 230V - III + T	Nº x mm <sup>2</sup> / A	-	4 x 2,5 / 25A
Tension 400V - III + N + T	Nº x mm <sup>2</sup> / A	5 x 50 / 125A	5 x 2,5 / 25A
<b>NET DIMENSIONS / D. WITH PACKING</b>			
Net / gross width	mm	1.270 / 1.330	
	inch	50 / 52,36	
Net / gross depth	mm	1.366 / 1.455	
	inch	53,78 / 57,28	
Net height / gross height without heating	mm	2.380 /*2.200	
	inch	93,70 / *86,61	
Net / gross weight	Kg	529 / 575	
	lb	1.166,25 / 1.267,66	
<b>OTHERS</b>			
Sound level	dB	67	

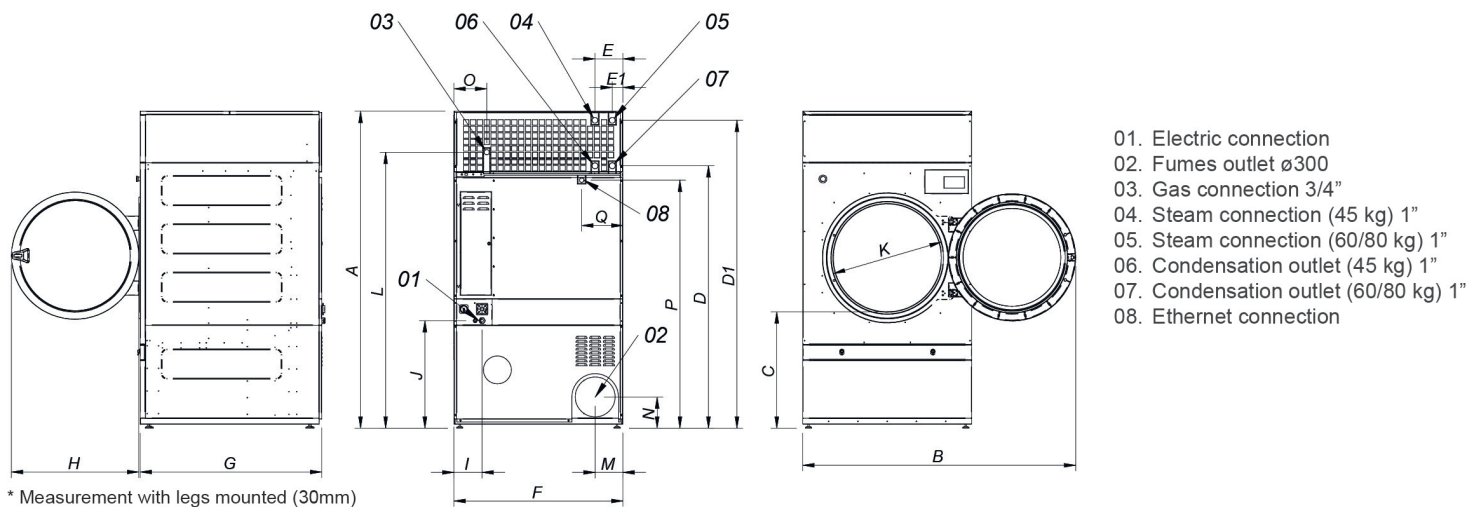

\* Measurement with legs mounted (30mm)

	A	B	C	D	D1	E	E1	F	G	H	I	J	K	L	M	N	O	P	Q
DO-45	2380*	2045	874	1981	2311	211	80	1270	1106	956	248	935	802	2088	214	240	244	160	1053
DO-60	2380*	2045	874	1981	2311	211	80	1270	1366	956	248	935	802	2088	214	240	244	160	1053
DO-80	2380*	2045	874	1981	2311	211	80	1270	1598	956	248	935	802	2088	214	240	244	160	1053

