



Primer

LS-18 T2

High spin washers

T2 CONTROL

User friendly and totally programmable 7" USB Connection. Online platform free of charge for programming, telemetry, data analysis...thanks to the IoT Videos on display (ads, instructions, etc.)
37 languages
8 dosing signals as standard

G FACTOR

High G-Factor: G-FACTOR 500 (11 - 18 kg), for 450 (22 - 80 kg) and 350 (100 - 120kg).
It reduces the residual moisture.

CONNECTIVITY

PRIMERLINK - Standard and free IoT connectivity. Remote technical service.
Management for laundries: OPL and COIN.
Remote payment: **App PRIMER LAUNDRY** (mod. LS-11 up to LS-45C).

EFFICIENCY

Optimal KG.
Intelligent consumption: automatic adjustment of water and soap consumptions (standard).
Water Recovery tanks ready: **SAVETANK & SAVETANK XL**.
Low water consumption.

VERSATILITY

Make to order: customisation.
OPL < > COIN (mod. LS-11 up to LS-45C).
Electric < > Hot water.
Drain valve < > Pump (LS-11-14).
Wet Cleaning.

ERGONOMICS

Easy opening/closing system for door lock.
Biggest door diameters:
• Ø 373 (11, 14 kg)
• Ø 460 (18, 22, 28 kg)
• Ø 560 (35, 45, 60, 80 kg)
• Ø 700 (100, 120 kg)

EASY MAINTENANCE

Hinged control panel: easy and ergonomic access.
Technical menu: statistics for technicians.

OTHERS

Grey skinplate outer casing.
Drum and tub in stainless steel AISI 304.
Detergent dispenser with 4 compartments.
Electronic control of imbalance with frequency control.
LOADING AID feature: water and rotation control.
CB and WRAS approved product. Option ETL.
REG4 standard certified by KIWA.



OPTIONS

- License IoT - PrimerLink
- DQ-2 Dosing pump kit. 2 pumps with guide support.
- Extra detergent dosage DB-1
- Double drain kit LS-14/18/22
- Ready for SAVETANK conn. 3/4" for washers LS/RS-11 to 28
- Normally closed valve LS-18/22
- Recirculation of bath water LS-18. Not with SAVETANK
- Leveling Feet LS-11/14/18/22/28
- Weighing sensor system on feet LS-11 to LS-45C. Incl. kit 6 extra dosing signals
- 6 extra dosing signals card LS-11 to 45C
- Silicone door gasket LS-18/22/28
- Reversible door: reverse door opening
- Steam kit LS-11/14/18/22
- Plinth MOPS with drawer LS-18/22 inox
- Plinth MOPS with drawer LS-18/22 skinplate
- Stainless steel plinth LS-18/22 to level all machines from top
- skinplate plinth LS-18/22 to level all machines from top
- Door base alignment plinth at 850mm in stainless steel LS-18/23
- Door base alignment plinth at 850mm on skinplate LS-18/23
- Stainless steel outer casing LS-18
- Stainless steel front panel LS-18
- 440 V III No N 50/60 Hz LS-18/22 (maritime)
- Several payment systems for self-service

DRUM		UNIT.		LS-18 T2	
Capacity 1/9		Kg		20	
Capacity 1/10		Kg		18	
Volume		l		180	
Diameter		mm		700	
Depth		mm		470	
GENERAL DETAILS					
Washing speed / Spining speed		r.p.m.		47 / 1.133	
G Factor		-		500	
Maximum force transmitted		KN		3,41 ±1,4	
Frequency-dynamic force		Hz		16	
Noise level		dB		< 70	
Coin laundry version		-		YES	
Double drain		-		OPT.	
Weighing system		-		OPT.	
Tilting door		-		NO	
DOOR					
Height center door / Height door		mm		765 / 450	
Diameter		mm		460	
POWER					
Motor		kW		2,2	
Electric heating power		kW		12	
Total electric power (electric model)		kW		12,75	
Total electric power (hw, steam model)		kW		2,2	
CONNECTIONS				E	HW/S
Tension 110V - I + N + T		Nº x mm² / A		-	-
Tension 230V - I + N + T		Nº x mm² / A		2x16+T - 63A	2x1,5+T - 16A
Tension 230V - III + T		Nº x mm² / A		3X6+T - 40A	-
Tension 400V - III + N + T		Nº x mm² / A		4x4+T - 32A	-
Steam inlet (Steam model)		inch		1/2"	1/2"
Maximum steam consumption (Steam model)		Kg/h		12	
Water inlet		inch		3/4"	
Water main pressuer		Kg/cm²		2-4	
Maximum water consumption*		l / h		118,3*	
Drain		mm/inch		3"	
Drainage capacity		Lit/min		200	
DIMENSIONS / PACKING DIMENSIONS					
Net Width/Gross width		mm		884 / 945	
Net Depth/Gross depth		mm		913 / 1.030	
Net Height / Gross height		mm		1.405 / 1.680	
Net weight / Gross weight		kg		344,5 / 388	
Volume		m³		1,63	

* Program number 20: LS-11 to LS-80C at 75% load / LS-100C and 120C at 100% load.



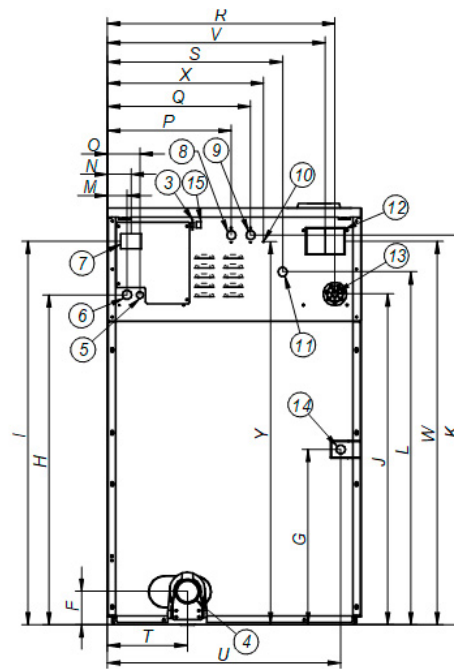
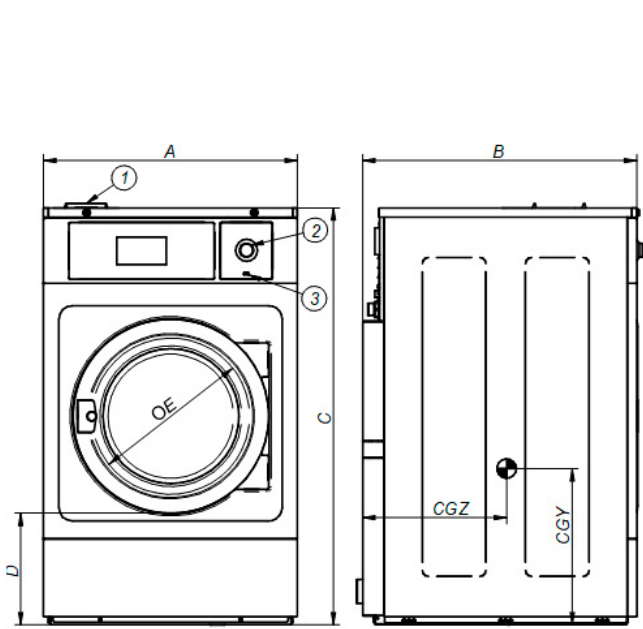

1. Soap dispenser
2. Emergency stop
3. USB port
4. Drain
5. Electric connection to liquid soap pumps
6. Electrical connection
7. Main switch
8. Auxiliar water inlet
9. Hot water inlet
10. Equipotential connection
11. Cold water inlet
12. Blur output / Water overload
13. Liquid soap connection
14. Steam connection
15. Ethernet port
16. Clean side light

		A	B	C	D	E	F	G	H	I	J	K	L	M	N	O	P	Q	R	S	T	U	V	W	X	Y	CGY	CGZ
LS-18	mm	884	913	1.405	450	460	125	380	1.135	1.303	1.138	1.322	1.207	61	74	101	429	509	802	640	322	814	772	1.303	569	1.297	464	702
	inch	34,80	35,94	55,31	17,72	18,11	4,92	14,96	44,68	51,30	44,80	52,05	47,52	2,40	2,91	3,98	16,89	20,04	31,57	25,20	12,68	32,05	30,39	51,30	22,40	51,06	18,27	27,64

